

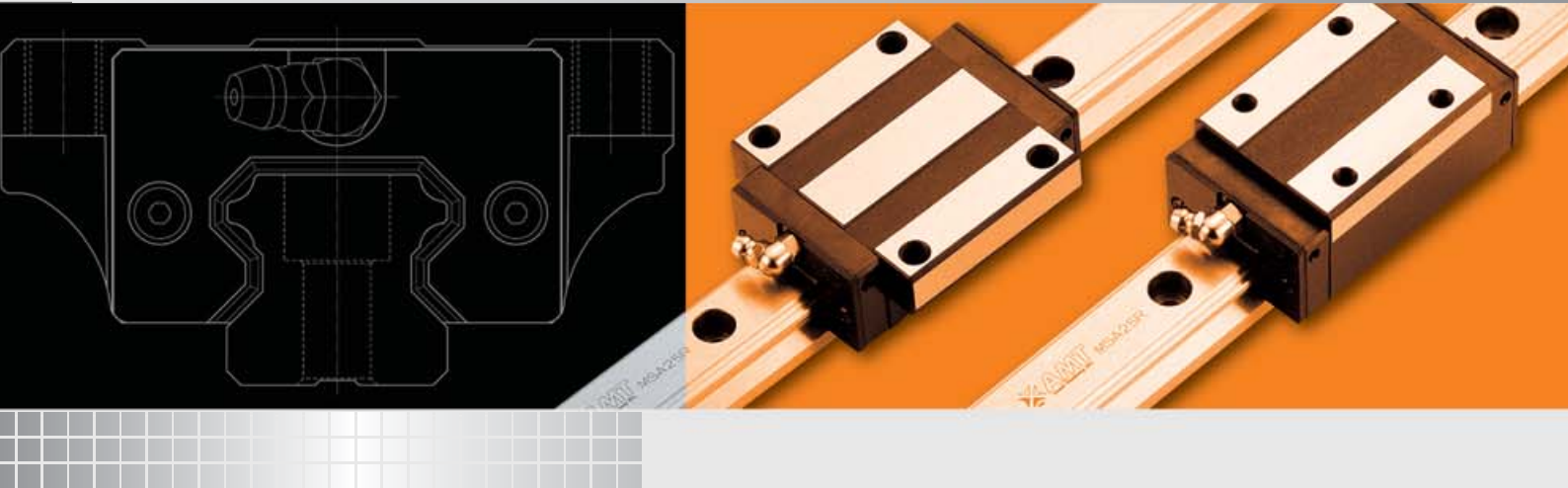

LINEAR GUIDEWAY



ADVANCED MOTION TECHNOLOGIES CORP.

No.73, Lane 20, Dafu Road, Shen Kang Hsiang,
Taichung Hsien 429, Taiwan

TEL: +886-4-25282984

FAX: +886-4-25121027

E-mail: amt.info@pmi-amt.com.tw

Web site: www.pmi-amt.com

Content

1. The Characteristics of AMT Linear Guideways	01
2. The Procedure of Select Linear Guideway	02
3. Load Rating and Service Life of Linear Guideway	03
3.1 Basic Static Load Rating (C_0)	03
3.2 Static Permissible Moment (M_0)	03
3.3 Static Safety Factor (f_s)	03
3.4 Basic Dynamic Load Rating (C)	04
3.5 Calculation of Nominal Life (L)	04
3.6 Calculation of Service Life in Time (L_h)	05
4. Friction Coefficient	06
5. Calculation of Working Load	07
6. Calculation of the Equivalent Load	10
7. The Calculation of the Mean Load	10
8. Calculation Example	12
9. Installation Direction of Linear Guideway	16
10. Fixing Methods of Linear Guideway	17
11. Installation of Linear Guideway	17
11.1 Installation of Linear Guideway When Machine Subjected to Vibration and Impact	17
11.2 Installation of Linear Guideway without Push Screws	19
11.3 The Installation of Carriage of Linear Guideway without the Reference Side for Master Rail	20
11.4 Accuracy Measurement after Installation	21
11.5 The Recommended Tightening Torque for Rails	22
12. Marking on Master Linear Guideway and Combined Case	22
12.1 Recognizing of Reference Side	22
12.2 Recognizing of Master Rail	23
12.3 Combined Use of Rail and Carriage	23
12.4 For Butt-joint Rail	23
13. The Relationship between the Direction of Lubrication and the Reference Side	24
14. Accuracy Standard	25
15. The Selection of Accuracy Grade	26
16. Preload and Rigidity	27
17. The Selection of Preload	27
18. Lubrication	27
19. Plastic Caps for rail mounting hole	30
20. Construction and Characteristics of MSA and MSB Series	31
21. MSA Series - Heavy Load Type	32
21.1 Carriage Type	32
21.2 Rail Type	32
21.3 Description of Specification	33
21.4 Accuracy Grade	35
21.5 Preload Grade and Rigidity	36
21.6 Dust Proof	37
21.7 The Shoulder Height and Corner Radius for Installation	38
21.8 Dimensional Tolerance of Mounting Surface	39
21.9 Tapped-hole Rail Dimensions	39
21.10 Rail Standard and Maximum Length	40
21.11 Dimensions of MSA-A / MSA-LA	41
21.12 Dimensions of MSA-E / MSA-LE	42
21.13 Dimensions of MSA-S / MSA-LS	43
22. MSB Series - Compact Type	44
22.1 Carriage Type	44
22.2 Rail Type	44
22.3 Description of Specification	45
22.4 Accuracy Grade	47
22.5 Preload Grade and Rigidity	48
22.6 Dust Proof	49
22.7 The Shoulder Height and Corner Radius for Installation	50
22.8 Dimensional Tolerance of Mounting Surface	51
22.9 Tapped-hole Rail Dimensions	51
22.10 Rail Standard and Maximum Length	52
22.11 Dimensions of MSB-TE / MSB-E	53
22.12 Dimensions of MSB-TS / MSB-S	54
23. AMT Linear Guideway with SL Lubricator	55
23.1 Construction and Features	55
23.2 Performance	56
23.3 Description of Specification	57
23.4 Dimensions of the SL Lubricator	58
AMT Linear Guideway Request Form	59

1. The Characteristics of **AMT** Linear Guideways

High positioning accuracy, high repeatability

The **AMT** linear guideway is a design of rolling motion with a low friction coefficient, and the difference between dynamic and static friction is very small. Therefore, the stick-slip will not occur when submicron feeding is making.

Low frictional resistance, high precision maintained for long period

The frictional resistance of a linear guideway is only 1/20th to 1/40th of that in a slide guide. With a linear guideway, a well lubrication can be easily achieved by supplying grease through the grease nipple on carriage or utilizing a centralized oil pumping system, thus the frictional resistance is decreased and the accuracy could be maintained for long period.

High rigidity with four-way load design

The optimum design of geometric mechanics makes the linear guideway to bear the load in all four directions, radial, reversed radial, and two lateral directions. Furthermore, the rigidity of linear guideway could be easily achieved by preloading carriage and by adding the number of carriages.

Suitable for high speed operation

Due to the characteristic of low frictional resistance, the required driving force is much lower than in other systems, thus the power consumption is small. Moreover, the temperature rising effect is small even under high speed operation.

Easy installation with interchangeability

Compared with the high-skill required scrapping process of conventional slide guide, the linear guideway can offer high precision even if the mounting surface is machined by milling or grinding. Moreover the interchangeability of linear guideway gives a convenience for installation and future maintenance.



2. The Procedure of Select Linear Guideway

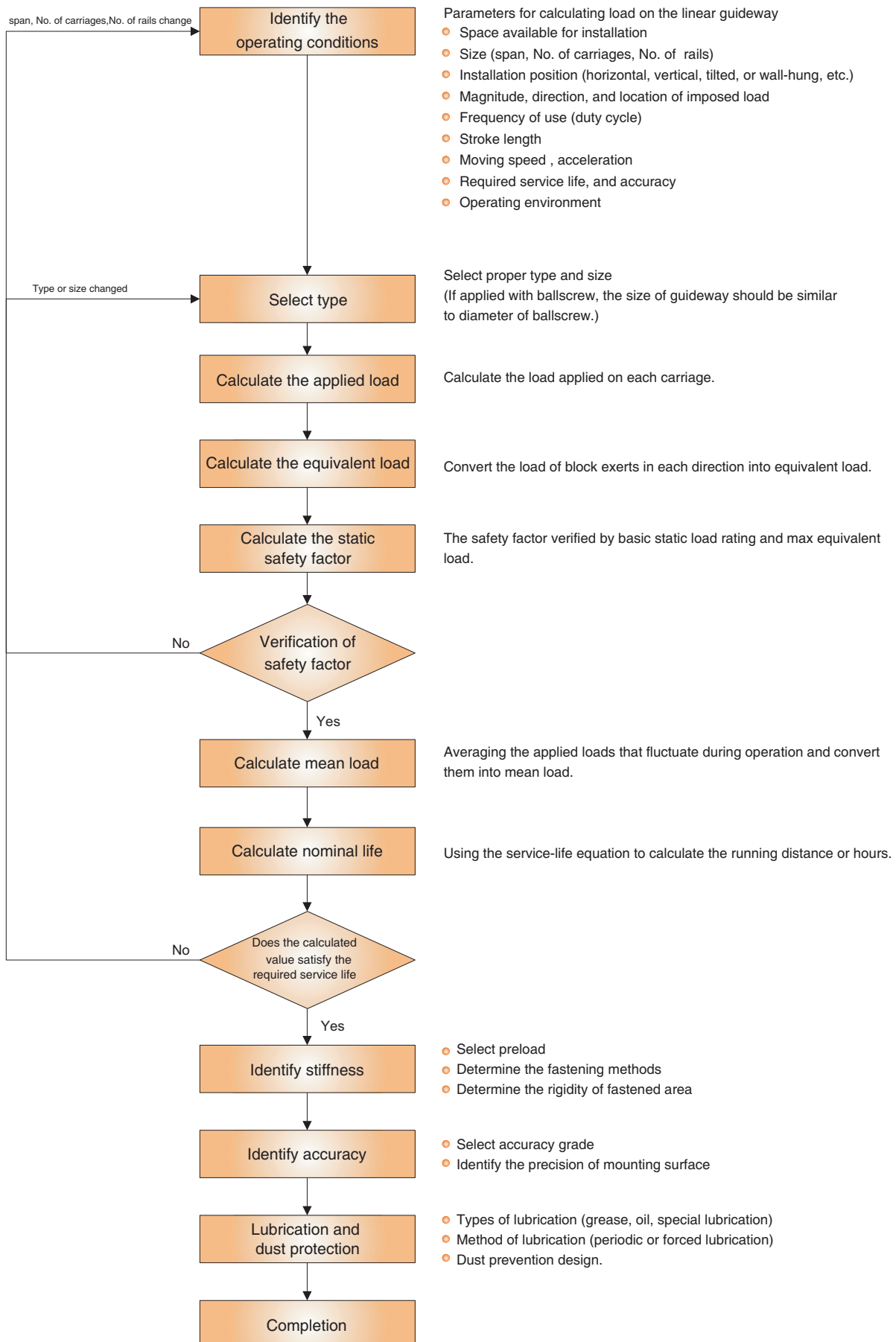

3. Load Rating and Service Life of Linear Guideway

To obtain a model which is most suitable for your service conditions of the linear guideway system, the load capacity and service life of the model must be taken into consideration.

To verify the static load capacity, the basic static load rating (C_0) is taken to obtain the static safety factor. The service life can be obtained by calculating the nominal life based on basic dynamic load rating. As the raceways or rolling balls are subjected repeated stresses, the service life of a linear guideway is defined as the total running distance that the linear guideway travel until flaking occurs.

3.1 Basic Static Load Rating (C_0)

A localized permanent deformation will develop between raceways and rolling balls when a linear guideway receives an excessive load or a large impact. If the magnitude of the deformation exceeds a certain limit, it could obstruct the smooth motion of the linear guideway.

The basic static load rating (C_0) refers to a static load in a given direction with a specific magnitude applied at the contact area under the most stress where the sum of permanent deformation develops between the raceway and rolling balls is 0.0001 times of the diameter of rolling ball. Therefore, the basic static load rating sets a limit on the static permissible load.

3.2 Static Permissible Moment (M_0)

When a moment is applied to a linear guideway, the rolling balls on both ends will receive the most stress among the stress distribution over the rolling balls in the system.

The static permissible moment (M_0) refers to a static moment in a given direction with specific magnitude applied at the contact area under the most stress where the sum of permanent deformation develops between the raceway and rolling balls is 0.0001 times the diameter of rolling ball. Therefore, the static permissible moment sets a limit on the static moment. In linear guideway system, the static permissible moment is defined as M_P 、 M_Y 、 M_R three directions. See Fig. 1.

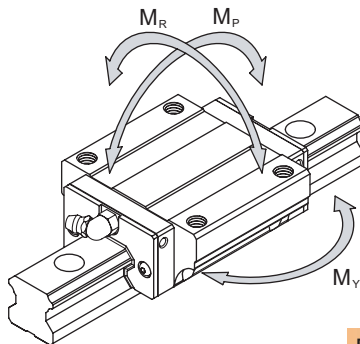

Fig.1 Static permissible moment

3.3 Static Safety Factor (f_s)

Due to the impact and vibration while the guideway at rest or moving, or the inertia from start and stop, the linear guideway may encounter with an unexpected external force. Therefore, the safety factor should be taken into consideration for effects of such operating loads.

The static safety factor (f_s) is a ratio of the basic static load rating (C_0) to the calculated working load. The static safety factor for different kinds of application is shown as Table 1.

$$f_s = \frac{C_0}{P} \quad \text{or} \quad f_s = \frac{M_0}{M}$$

f_s : Static safety factor

C_0 : Basic static load rating (N)

M_0 : Static permissible moment (N · m)

P : Calculated working load (N)

M : Calculated moment (N · m)

Table 1 Standard value of static safety factor

Machine Type	Load Condition	fs (Lower limit)
Regular industrial machine	Normal loading condition	1.0~1.3
	With impact and vibration	2.0~3.0
Machine tool	Normal loading condition	1.0~1.5
	With impact and vibration	2.5~7.0

3.4 Basic Dynamic Load Rating (C)

Even when identical linear guideways in a group are manufactured in the same way or applied under the same condition, the service life may be varied. Thus, the service life is used as an indicator for determining the service life of a linear guideway system.

The nominal life (L) is defined as the total running distance that 90% of identical linear guideways in a group, when they are applied under the same conditions, can work without developing flaking.

The basic dynamic load rating (C) can be used to calculate the service life when linear guideway system response to a load. The basic dynamic load rating (C) is defined as a load in a given direction and with a given magnitude that when a group of linear guideways operate under the same conditions, the nominal life of the linear guideway is 50 km. (if the rolling element is ball)

3.5 Calculation of Nominal Life (L)

The nominal life of a linear guideway can be affected by the actual working load. The nominal life can be calculated based on selected basic dynamic load rating and actual working load.

The nominal life of linear guideway system could be influenced widely by environmental factors such like hardness of raceway, environmental temperature, motion conditions, thus these factors should be considered for calculation of nominal life.

$$L = \left(\frac{f_H \times f_T}{f_W} \times \frac{C}{P} \right)^3 \times 50$$

L : Nominal life (km)

C : Basic dynamic load rating (N)

P : Working load (N)

f_H : Hardness factor (see Fig.2)

f_T : Temperature factor (see Fig.3)

f_W : Load factor (see Table 2)

Hardness factor f_H

In order to ensure the optimum load capacity of linear guideway system, the hardness of raceway must be HRC58~64. If the hardness is lower than this range, the permissible load and nominal life will be decreased. For this reason, the basic dynamic load rating and the basic static load rating should be multiplied by hardness factor for rating calculation. See Fig. 2. The hardness requirement of **AMT** linear guideway is above HRC58, thus the $f_H=1.0$.

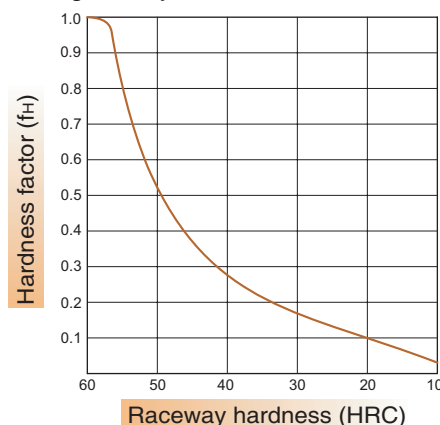

Fig. 2 Hardness factor

Temperature factor f_T

When operating temperature higher than 100°C, the nominal life will be degraded. Therefore, the basic dynamic and static load rating should be multiplied by temperature factor for rating calculation. See Fig. 3.

The assemble parts of **AMT** guideway are made of plastic and rubber, therefore, the operating temperature below 100°C is strongly recommend. For special need, please contact us.

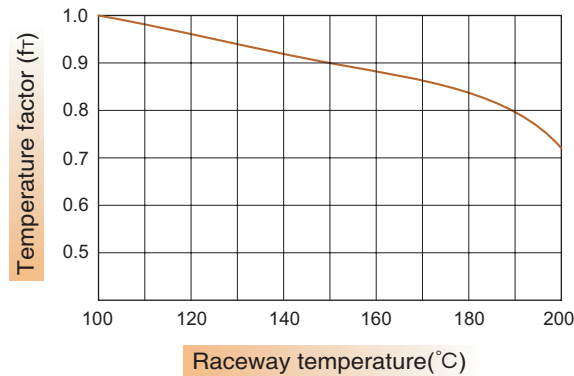

Fig. 3 Temperature factor

Load factor f_w

Although the working load of liner guideway system can be obtained by calculation, the actual load is mostly higher than calculated value. This is because the vibration and impact, caused by mechanical reciprocal motion, are difficult to be estimated. This is especially true when the vibration from high speed operation and the impact from repeated start and stop.

Therefore, for consideration of speed and vibration, the basic dynamic load rating should be divided by the empirical load factor. See Table 2.

Table 2 Load factor (f_w)

Motion Condition	Operating Speed	f_w
No impact & vibration	$V \leq 15$ m/min	1.0~1.2
Slight impact & vibration	$15 < V \leq 60$ m/min	1.2~1.5
Moderate impact & vibration	$60 < V \leq 120$ m/min	1.5~2.0
Strong impact & vibration	$V \geq 120$ m/min	2.0~3.5

3.6 Calculation of Service Life in Time (L_h)

When the nominal life (L) is obtained, the service life in hours can be calculated by using the following equation when stroke length and reciprocating cycles are constant.

$$L_h = \frac{L \times 10^3}{2 \times l_s \times n_1 \times 60}$$

L_h : Service life in hours (hr)

L : Nominal life (km)

l_s : Stroke length (m)

n_1 : No. of reciprocating cycles per minute (min^{-1})

4. Friction Coefficient

A linear guideway manipulates linear motion by circulating balls between the rail and the carriage. In which type of motion, the frictional resistance of linear guideway can be reduced to 1/20th to 1/40th of that in a slide guide. This is especially true in static friction which is much smaller than that in other systems. Moreover, the difference between static and dynamic friction is very little, so that the stick-slip situation does not occur. As such low friction, the submicron feeding can be carried out. The frictional resistance of a linear guideway system can be varied with the magnitude of load and preload, the viscosity resistance of lubricant, and other factors.

The frictional resistance can be calculated by the following equation base on working load and seals resistance. Generally, the friction coefficient will be different from series to series, the friction coefficient of MSA and MSB series is 0.002~0.003 (without considering the seal resistance).

$$F = \mu \times P + f$$

F : Frictional resistance (kgf)

μ : Dynamic friction coefficient

P : Working load (kgf)

f : Seal resistance (kgf)

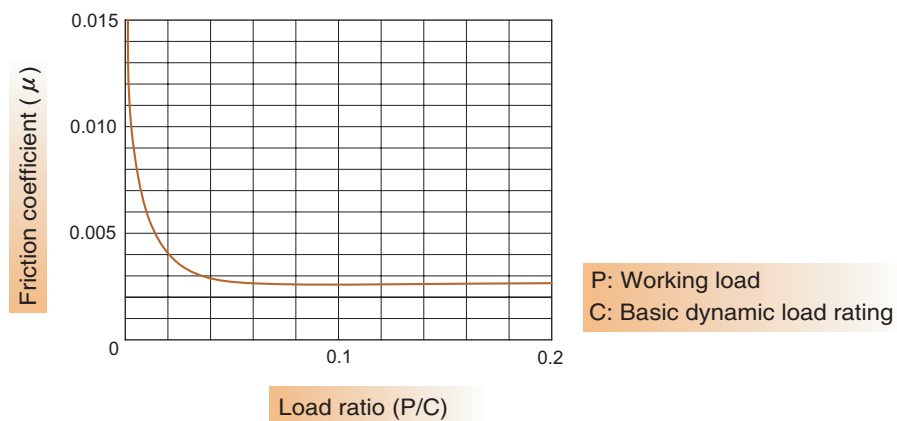

Fig. 4 Relationship between working load and friction coefficient

5. Calculation of Working Load

The load applied to a linear guideway system could be varied with several factors such as the location of the center gravity of an object, the location of the thrust, and the inertial forces due to acceleration and deceleration during starting and stopping.

To select a correct linear guideway system, the above conditions must be considered for determining the magnitude of applied load.

Examples for calculating working load

Type	Operation Conditions	Equations
<p><u>Horizontal application:</u> Uniform motion or at rest</p>		$P_1 = \frac{F}{4} + \frac{F \cdot l_3}{2 \cdot l_1} - \frac{F \cdot l_4}{2 \cdot l_2}$ $P_2 = \frac{F}{4} - \frac{F \cdot l_3}{2 \cdot l_1} - \frac{F \cdot l_4}{2 \cdot l_2}$ $P_3 = \frac{F}{4} - \frac{F \cdot l_3}{2 \cdot l_1} + \frac{F \cdot l_4}{2 \cdot l_2}$ $P_4 = \frac{F}{4} + \frac{F \cdot l_3}{2 \cdot l_1} + \frac{F \cdot l_4}{2 \cdot l_2}$
<p><u>Overhung horizontal application:</u> Uniform motion or at rest</p>		$P_1 = \frac{F}{4} + \frac{F \cdot l_3}{2 \cdot l_1} + \frac{F \cdot l_4}{2 \cdot l_2}$ $P_2 = \frac{F}{4} - \frac{F \cdot l_3}{2 \cdot l_1} + \frac{F \cdot l_4}{2 \cdot l_2}$ $P_3 = \frac{F}{4} - \frac{F \cdot l_3}{2 \cdot l_1} - \frac{F \cdot l_4}{2 \cdot l_2}$ $P_4 = \frac{F}{4} + \frac{F \cdot l_3}{2 \cdot l_1} - \frac{F \cdot l_4}{2 \cdot l_2}$
<p><u>Vertical application:</u> Uniform motion or at rest</p>		$P_1 = P_2 = P_3 = P_4 = \frac{F \cdot l_3}{2 \cdot l_1}$ $P_{1r} = P_{2r} = P_{3r} = P_{4r} = \frac{F \cdot l_4}{2 \cdot l_1}$

Wall installation application:
Uniform motion or at rest

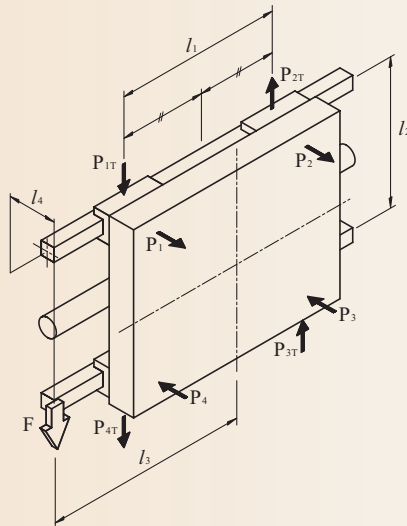

$$P_1 = P_2 = P_3 = P_4 = \frac{F \cdot l_4}{2 \cdot l_2}$$

$$P_{1T} = P_{4T} = \frac{F}{4} + \frac{F \cdot l_3}{2 \cdot l_1}$$

$$P_{2T} = P_{3T} = \frac{F}{4} - \frac{F \cdot l_3}{2 \cdot l_1}$$

Laterally tilted application

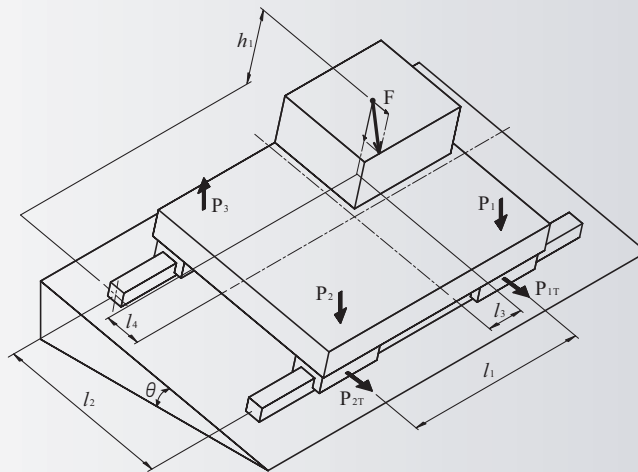

$$P_1 = \frac{F \cdot \cos \theta}{4} + \frac{F \cdot \cos \theta \cdot l_3}{2 \cdot l_1} - \frac{F \cdot \cos \theta \cdot l_4}{2 \cdot l_2} + \frac{F \cdot \sin \theta \cdot h_1}{2 \cdot l_2}$$

$$P_2 = \frac{F \cdot \cos \theta}{4} - \frac{F \cdot \cos \theta \cdot l_3}{2 \cdot l_1} - \frac{F \cdot \cos \theta \cdot l_4}{2 \cdot l_2} + \frac{F \cdot \sin \theta \cdot h_1}{2 \cdot l_2}$$

$$P_3 = \frac{F \cdot \cos \theta}{4} - \frac{F \cdot \cos \theta \cdot l_3}{2 \cdot l_1} + \frac{F \cdot \cos \theta \cdot l_4}{2 \cdot l_2} - \frac{F \cdot \sin \theta \cdot h_1}{2 \cdot l_2}$$

$$P_4 = \frac{F \cdot \cos \theta}{4} + \frac{F \cdot \cos \theta \cdot l_3}{2 \cdot l_1} + \frac{F \cdot \cos \theta \cdot l_4}{2 \cdot l_2} - \frac{F \cdot \sin \theta \cdot h_1}{2 \cdot l_2}$$

$$P_{1T} = P_{4T} = \frac{F \cdot \sin \theta}{4} + \frac{F \cdot \sin \theta \cdot l_3}{2 \cdot l_1}$$

$$P_{2T} = P_{3T} = \frac{F \cdot \sin \theta}{4} - \frac{F \cdot \sin \theta \cdot l_3}{2 \cdot l_1}$$

Longitudinally tilted application

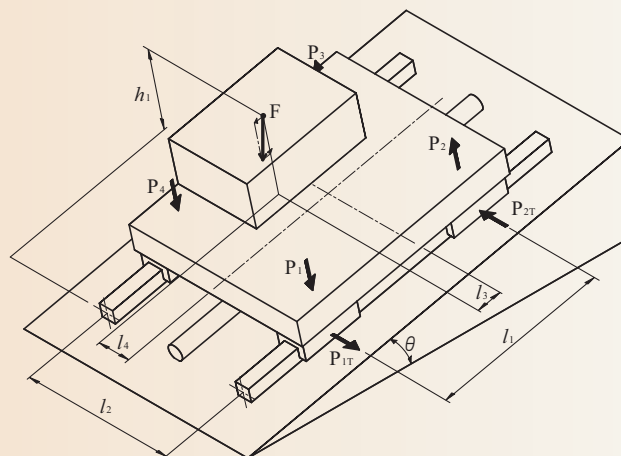

$$P_1 = \frac{F \cdot \cos \theta}{4} + \frac{F \cdot \cos \theta \cdot l_3}{2 \cdot l_1} - \frac{F \cdot \cos \theta \cdot l_4}{2 \cdot l_2} + \frac{F \cdot \sin \theta \cdot h_1}{2 \cdot l_1}$$

$$P_2 = \frac{F \cdot \cos \theta}{4} - \frac{F \cdot \cos \theta \cdot l_3}{2 \cdot l_1} - \frac{F \cdot \cos \theta \cdot l_4}{2 \cdot l_2} - \frac{F \cdot \sin \theta \cdot h_1}{2 \cdot l_1}$$

$$P_3 = \frac{F \cdot \cos \theta}{4} - \frac{F \cdot \cos \theta \cdot l_3}{2 \cdot l_1} + \frac{F \cdot \cos \theta \cdot l_4}{2 \cdot l_2} - \frac{F \cdot \sin \theta \cdot h_1}{2 \cdot l_1}$$

$$P_4 = \frac{F \cdot \cos \theta}{4} + \frac{F \cdot \cos \theta \cdot l_3}{2 \cdot l_1} + \frac{F \cdot \cos \theta \cdot l_4}{2 \cdot l_2} + \frac{F \cdot \sin \theta \cdot h_1}{2 \cdot l_1}$$

$$P_{1T} = P_{4T} = + \frac{F \cdot \sin \theta \cdot l_4}{2 \cdot l_1}$$

$$P_{2T} = P_{3T} = - \frac{F \cdot \sin \theta \cdot l_4}{2 \cdot l_1}$$

Horizontal application:
Subjected to inertia

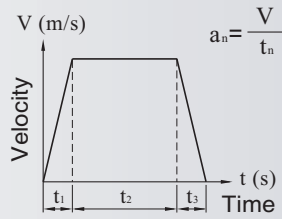
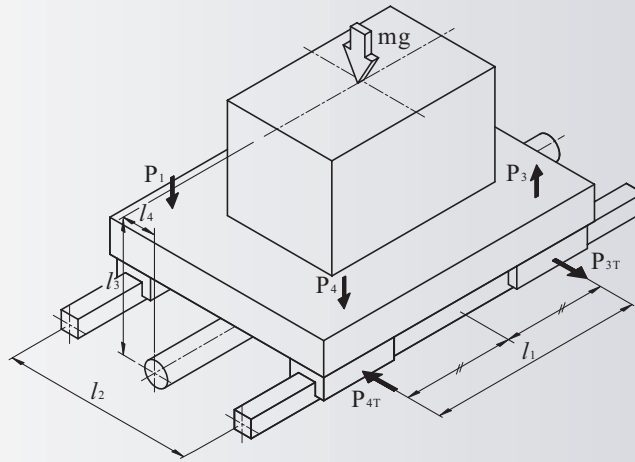

Velocity diagram

During acceleration

$$P_1 = P_4 = \frac{mg}{4} - \frac{m \cdot a_i \cdot l_3}{2 \cdot l_1}$$

$$P_2 = P_3 = \frac{mg}{4} + \frac{m \cdot a_i \cdot l_3}{2 \cdot l_1}$$

$$P_{1T} = P_{2T} = P_{3T} = P_{4T} = \frac{m \cdot a_i \cdot l_4}{2 \cdot l_1}$$

In uniform motion

$$P_{1T} = P_{2T} = P_{3T} = P_{4T} = \frac{mg}{4}$$

During deceleration

$$P_1 = P_4 = \frac{mg}{4} + \frac{m \cdot a_s \cdot l_3}{2 \cdot l_1}$$

$$P_2 = P_3 = \frac{mg}{4} - \frac{m \cdot a_s \cdot l_3}{2 \cdot l_1}$$

$$P_{1T} = P_{2T} = P_{3T} = P_{4T} = \frac{m \cdot a_s \cdot l_4}{2 \cdot l_1}$$

Vertical application:
Subjected to inertia

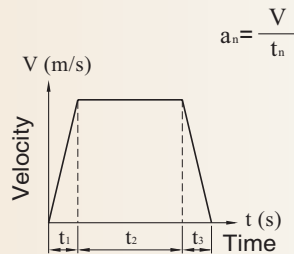
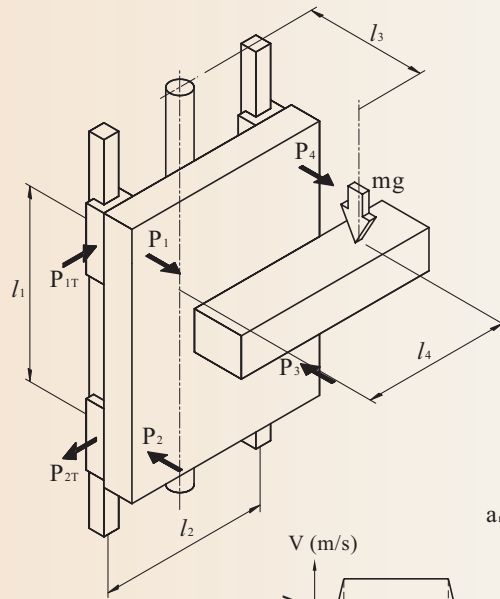

Velocity diagram

During acceleration

$$P_1 = P_2 = P_3 = P_4 = \frac{m \cdot (g + a_i) \cdot l_3}{2 \cdot l_1}$$

$$P_{1T} = P_{2T} = P_{3T} = P_{4T} = \frac{m \cdot (g + a_i) \cdot l_4}{2 \cdot l_1}$$

In uniform motion

$$P_1 = P_2 = P_3 = P_4 = \frac{m \cdot g \cdot l_3}{2 \cdot l_1}$$

$$P_{1T} = P_{2T} = P_{3T} = P_{4T} = \frac{m \cdot g \cdot l_4}{2 \cdot l_1}$$

During deceleration

$$P_1 = P_2 = P_3 = P_4 = \frac{m \cdot (g - a_s) \cdot l_3}{2 \cdot l_1}$$

$$P_{1T} = P_{2T} = P_{3T} = P_{4T} = \frac{m \cdot (g - a_s) \cdot l_4}{2 \cdot l_1}$$

6. Calculation of the Equivalent Load

The linear guideway system can take up loads and moments in all four directions those are radial load, reverse-radial load, and lateral load simultaneously. When more than one load is exerted on linear guideway system simultaneously, all loads could be converted into radial or lateral equivalent load for calculating service life and static safety factor. MSA and MSB series guideway has four-way equal load design. The calculation of equivalent load for the use of two or more linear guideways is shown as below.

$$P_E = |P_R| + |P_T|$$

P_E : Equivalent load (N)

P_R : Radial or reverse-radial load (N)

P_T : Lateral load (N)

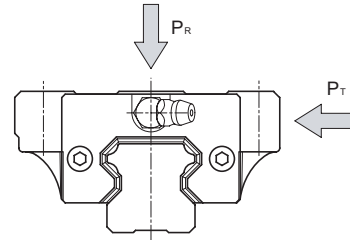

For the case of mono rail, the moment effect should be considered. The equation is:

$$P_E = |P_R| + |P_T| + C_0 \cdot \frac{|M|}{M_R}$$

P_E : Equivalent load(N)

P_R : Radial or reverse-radial load(N)

P_T : Lateral load (N)

C_0 : Basic static load rating (N)

M : Calculated moment (N · m)

M_R : Permissible static moment (N · m)

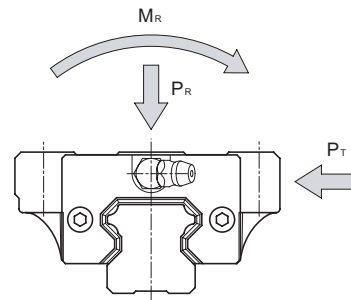

7. The Calculation of the Mean Load

When a linear guideway system receives varying loads, the service life could be calculated in consideration of varying loads of the host-system operation conditions.

The mean load (P_m) is the load that the service life is equivalent to the system which under the varying load conditions.

If the rolling elements are balls, the equation of mean load is:

$$P_m = \sqrt[3]{\frac{L}{L} \cdot \sum_{n=1}^n (P_n^3 \cdot L_n)}$$

P_m : Mean load (N)

P_n : Varying load (N)

L : Total running distance (mm)

L_n : Running distance under load P_n (mm)

Examples for calculating mean load

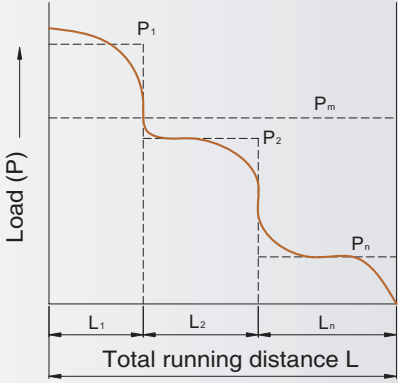
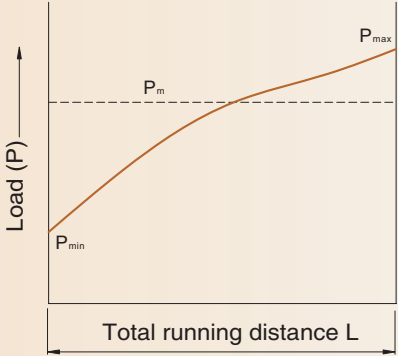
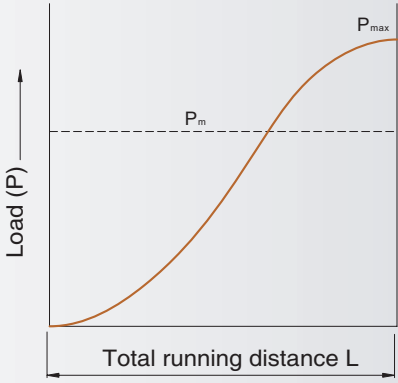
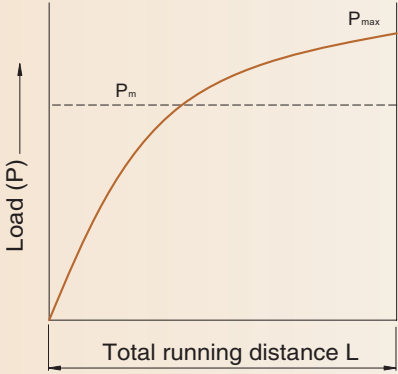
Types of Varying Load	Calculation of Mean Load
<p>Loads that change stepwise</p> 	$P_m = \sqrt[3]{\frac{1}{L}(P_1^3 \cdot L_1 + P_2^3 \cdot L_2 + \dots + P_n^3 \cdot L_n)}$ <p> P_m : Mean load (N) P_n : Varying load (N) L : Total running distance (mm) L_n : Running distance under load P_n (mm) </p>
<p>Loads that change monotonously</p> 	$P_m \cong \frac{1}{3}(P_{min} + 2 \cdot P_{max})$ <p> P_m : Mean load (N) P_{min} : Minimum load (N) P_{max} : Maximum load (N) </p>
<p>Loads that change sinusoidally</p> 	$P_m \cong 0.65 \cdot P_{max}$ <p> P_m : Mean load (N) P_{max} : Maximum load (N) </p>
<p>Loads that change sinusoidally</p> 	$P_m \cong 0.75 \cdot P_{max}$ <p> P_m : Mean load (N) P_{max} : Maximum load (N) </p>

8. Calculation Example

Operation conditions

Model : MSA35LA2SSFC + R2520-20/20 P II

Basic dynamic load rating : C = 50.8 kN

Basic static load rating : C₀ = 81.8 kN

Mass $m_1 = 700$ kg

$m_2 = 450$ kg

Velocity $V = 0.75$ m/s

Time $t_1 = 0.05$ s

$t_2 = 1.9$ s

$t_3 = 0.15$ s

Acceleration $a_1 = 15$ m/s²

$a_3 = 5$ m/s²

Stroke $l_s = 1500$ mm

Distance $l_1 = 650$ mm

$l_2 = 450$ mm

$l_3 = 135$ mm

$l_4 = 60$ mm

$l_5 = 175$ mm

$l_6 = 400$ mm

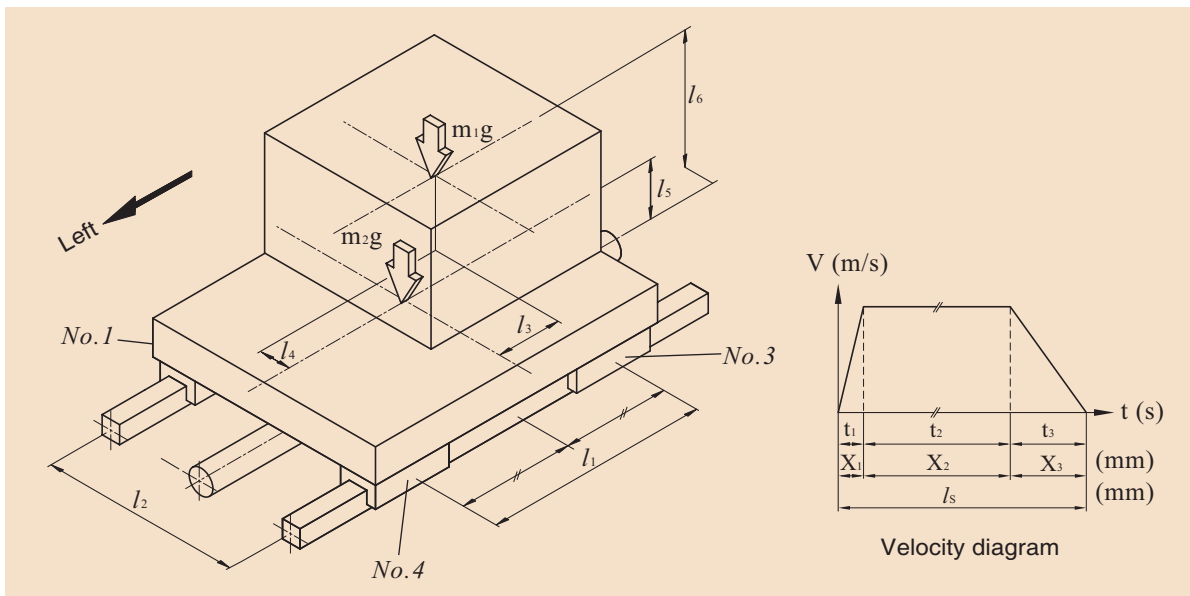

1 Calculate the load that each carriage exerts

1-1 Uniform motion, Radial load P_n

$$P_1 = \frac{m_1 g}{4} - \frac{m_1 g \cdot l_3}{2l_1} + \frac{m_1 g \cdot l_4}{2l_2} + \frac{m_2 g}{4}$$

$$= 2562.4 \text{ N}$$

$$P_2 = \frac{m_1 g}{4} + \frac{m_1 g \cdot l_3}{2l_1} + \frac{m_1 g \cdot l_4}{2l_2} + \frac{m_2 g}{4}$$

$$= 3987.2 \text{ N}$$

$$P_3 = \frac{m_1 g}{4} + \frac{m_1 g \cdot l_3}{2l_1} - \frac{m_1 g \cdot l_4}{2l_2} + \frac{m_2 g}{4}$$

$$= 3072.6 \text{ N}$$

$$P_4 = \frac{m_1 g}{4} - \frac{m_1 g \cdot l_3}{2l_1} - \frac{m_1 g \cdot l_4}{2l_2} + \frac{m_2 g}{4}$$

$$= 1647.8 \text{ N}$$

1-2 During acceleration to the left, Radial load $P_n l a_1$

$$P_1 l a_1 = P_1 - \frac{m_1 \cdot a_1 \cdot l_6}{2l_1} - \frac{m_2 \cdot a_1 \cdot l_5}{2l_1}$$

$$= -1577 \text{ N}$$

$$P_2 l a_1 = P_2 + \frac{m_1 \cdot a_1 \cdot l_6}{2l_1} + \frac{m_2 \cdot a_1 \cdot l_5}{2l_1}$$

$$= 8126.6 \text{ N}$$

$$P_3 l a_1 = P_3 + \frac{m_1 \cdot a_1 \cdot l_6}{2l_1} + \frac{m_2 \cdot a_1 \cdot l_5}{2l_1}$$

$$= 7212 \text{ N}$$

$$P_4 l a_1 = P_4 - \frac{m_1 \cdot a_1 \cdot l_6}{2l_1} - \frac{m_2 \cdot a_1 \cdot l_5}{2l_1}$$

$$= -2491.6 \text{ N}$$

Lateral load $P_{t_n}l_{a1}$

$$P_{t_1}l_{a_1} = -\frac{m_1 \cdot a_1 \cdot l_4}{2l_1} = -484.6 \text{ N}$$

$$P_{t_2}l_{a_1} = \frac{m_1 \cdot a_1 \cdot l_4}{2l_1} = 484.6 \text{ N}$$

$$P_{t_3}l_{a_1} = \frac{m_1 \cdot a_1 \cdot l_4}{2l_1} = 484.6 \text{ N}$$

$$P_{t_4}l_{a_1} = -\frac{m_1 \cdot a_1 \cdot l_4}{2l_1} = -484.6 \text{ N}$$

1-3 During deceleration to the left, Radial load $P_{n}l_{a3}$

$$P_1l_{a_3} = P_1 + \frac{m_1 \cdot a_3 \cdot l_6}{2l_1} + \frac{m_2 \cdot a_3 \cdot l_5}{2l_1}$$

$$= 3942.2 \text{ N}$$

$$P_2l_{a_3} = P_2 - \frac{m_1 \cdot a_3 \cdot l_6}{2l_1} - \frac{m_2 \cdot a_3 \cdot l_5}{2l_1}$$

$$= 2607.4 \text{ N}$$

$$P_3l_{a_3} = P_3 - \frac{m_1 \cdot a_3 \cdot l_6}{2l_1} - \frac{m_2 \cdot a_3 \cdot l_5}{2l_1}$$

$$= 1692.8 \text{ N}$$

$$P_4l_{a_3} = P_4 + \frac{m_1 \cdot a_3 \cdot l_6}{2l_1} + \frac{m_2 \cdot a_3 \cdot l_5}{2l_1}$$

$$= 3027.6 \text{ N}$$

Lateral load $P_{t_n}l_{a3}$

$$P_{t_1}l_{a_3} = \frac{m_1 \cdot a_3 \cdot l_4}{2l_1} = 161.5 \text{ N}$$

$$P_{t_2}l_{a_3} = -\frac{m_1 \cdot a_3 \cdot l_4}{2l_1} = -161.5 \text{ N}$$

$$P_{t_3}l_{a_3} = -\frac{m_1 \cdot a_3 \cdot l_4}{2l_1} = 161.5 \text{ N}$$

$$P_{t_4}l_{a_3} = \frac{m_1 \cdot a_3 \cdot l_4}{2l_1} = -161.5 \text{ N}$$

1-4 During acceleration to the right, Radial load $P_{n}r_{a1}$

$$P_1r_{a_1} = P_1 + \frac{m_1 \cdot a_1 \cdot l_6}{2l_1} + \frac{m_2 \cdot a_1 \cdot l_5}{2l_1}$$

$$= 6701.8 \text{ N}$$

$$P_2r_{a_1} = P_2 - \frac{m_1 \cdot a_1 \cdot l_6}{2l_1} - \frac{m_2 \cdot a_1 \cdot l_5}{2l_1}$$

$$= -152.2 \text{ N}$$

$$P_3r_{a_1} = P_3 - \frac{m_1 \cdot a_1 \cdot l_6}{2l_1} - \frac{m_2 \cdot a_1 \cdot l_5}{2l_1}$$

$$= -1066.8 \text{ N}$$

$$P_4r_{a_1} = P_4 + \frac{m_1 \cdot a_1 \cdot l_6}{2l_1} + \frac{m_2 \cdot a_1 \cdot l_5}{2l_1}$$

$$= 5787.2 \text{ N}$$

Lateral load $P_{t_n}r_{a1}$

$$P_{t_1}r_{a_1} = \frac{m_1 \cdot a_1 \cdot l_4}{2l_1} = 484.6 \text{ N}$$

$$P_{t_2}r_{a_1} = -\frac{m_1 \cdot a_1 \cdot l_4}{2l_1} = -484.6 \text{ N}$$

$$P_{t_3}r_{a_1} = -\frac{m_1 \cdot a_1 \cdot l_4}{2l_1} = -484.6 \text{ N}$$

$$P_{t_4}r_{a_1} = \frac{m_1 \cdot a_1 \cdot l_4}{2l_1} = 484.6 \text{ N}$$

1-5 During deceleration to the right, Radial load $P_{n}r_{a3}$

$$P_1r_{a_3} = P_1 - \frac{m_1 \cdot a_3 \cdot l_6}{2l_1} - \frac{m_2 \cdot a_3 \cdot l_5}{2l_1}$$

$$= 1182.6 \text{ N}$$

$$P_2r_{a_3} = P_2 + \frac{m_1 \cdot a_3 \cdot l_6}{2l_1} + \frac{m_2 \cdot a_3 \cdot l_5}{2l_1}$$

$$= 5367 \text{ N}$$

$$P_3r_{a_3} = P_3 + \frac{m_1 \cdot a_3 \cdot l_6}{2l_1} + \frac{m_2 \cdot a_3 \cdot l_5}{2l_1}$$

$$= 4452.4 \text{ N}$$

$$P_4r_{a_3} = P_4 - \frac{m_1 \cdot a_3 \cdot l_6}{2l_1} - \frac{m_2 \cdot a_3 \cdot l_5}{2l_1}$$

$$= 268 \text{ N}$$

Lateral load $P_{t_{nr}ra_1}$

$$P_{t_1ra_3} = -\frac{m_1 \cdot a_3 \cdot l_4}{2l_1} = -161.5 \text{ N}$$

$$P_{t_3ra_3} = \frac{m_1 \cdot a_3 \cdot l_4}{2l_1} = 161.5 \text{ N}$$

$$P_{t_2ra_3} = \frac{m_1 \cdot a_3 \cdot l_4}{2l_1} = 161.5 \text{ N}$$

$$P_{t_4ra_3} = -\frac{m_1 \cdot a_3 \cdot l_4}{2l_1} = -161.5 \text{ N}$$

2 Calculate equivalent load

2-1 In uniform motion

$$P_{E1} = P_1 = 2562.4 \text{ N}$$

$$P_{E3} = P_3 = 3072.6 \text{ N}$$

$$P_{E2} = P_2 = 3987.2 \text{ N}$$

$$P_{E4} = P_4 = 1647.8 \text{ N}$$

2-2 During acceleration to the left

$$P_{E1}la_1 = |P_1la_1| + |Pt_1la_1| = 2061.6 \text{ N}$$

$$P_{E3}la_1 = |P_3la_1| + |Pt_3la_1| = 7696.6 \text{ N}$$

$$P_{E2}la_1 = |P_2la_1| + |Pt_2la_1| = 8611.2 \text{ N}$$

$$P_{E4}la_1 = |P_4la_1| + |Pt_4la_1| = 2976.2 \text{ N}$$

2-3 During deceleration to the left

$$P_{E1}la_3 = |P_1la_3| + |Pt_1la_3| = 4103.7 \text{ N}$$

$$P_{E3}la_3 = |P_3la_3| + |Pt_3la_3| = 1854.3 \text{ N}$$

$$P_{E2}la_3 = |P_2la_3| + |Pt_2la_3| = 2768.9 \text{ N}$$

$$P_{E4}la_3 = |P_4la_3| + |Pt_4la_3| = 3189.1 \text{ N}$$

2-4 During acceleration to the right

$$P_{E1}ra_1 = |P_1la_1| + |Pt_1la_1| = 7186.4 \text{ N}$$

$$P_{E3}ra_1 = |P_3la_1| + |Pt_3la_1| = 1551.4 \text{ N}$$

$$P_{E2}ra_1 = |P_2la_1| + |Pt_2la_1| = 636.8 \text{ N}$$

$$P_{E4}ra_1 = |P_4la_1| + |Pt_4la_1| = 6271.8 \text{ N}$$

2-5 During deceleration to the right

$$P_{E1}ra_3 = |P_1la_3| + |Pt_1la_3| = 1344.1 \text{ N}$$

$$P_{E3}ra_3 = |P_3la_3| + |Pt_3la_3| = 4613.9 \text{ N}$$

$$P_{E2}ra_3 = |P_2la_3| + |Pt_2la_3| = 5528.5 \text{ N}$$

$$P_{E4}ra_3 = |P_4la_3| + |Pt_4la_3| = 429.5 \text{ N}$$

3 Calculation of static factor

From above, the maximum load is exerted on carriage No.2 when during acceleration of the 2nd linear guideway to the left.

$$f_s = \frac{C_o}{P_{E2}la_1} = \frac{81.8 \times 10^3}{8611.2} = 9.5$$

4 Calculate the mean load on each carriage P_{m_n}

$$P_{m1} = \sqrt[3]{\frac{(P_{E1} l a_1^3 \cdot X_1 + P_{E1}^3 \cdot X_2 + P_{E1} l a_3^3 \cdot X_3 + P_{E1} r a_1^3 \cdot X_1 + P_{E1}^3 \cdot X_2 + P_{E1} r a_3^3 \cdot X_3)}{2l_s}}$$

$$= 2700.7 \text{ N}$$

$$P_{m2} = \sqrt[3]{\frac{(P_{E2} l a_1^3 \cdot X_1 + P_{E2}^3 \cdot X_2 + P_{E2} l a_3^3 \cdot X_3 + P_{E2} r a_1^3 \cdot X_1 + P_{E2}^3 \cdot X_2 + P_{E2} r a_3^3 \cdot X_3)}{2l_s}}$$

$$= 4077.2 \text{ N}$$

$$P_{m3} = \sqrt[3]{\frac{(P_{E3} l a_1^3 \cdot X_1 + P_{E3}^3 \cdot X_2 + P_{E3} l a_3^3 \cdot X_3 + P_{E3} r a_1^3 \cdot X_1 + P_{E3}^3 \cdot X_2 + P_{E3} r a_3^3 \cdot X_3)}{2l_s}}$$

$$= 3187.7 \text{ N}$$

$$P_{m4} = \sqrt[3]{\frac{(P_{E4} l a_1^3 \cdot X_1 + P_{E4}^3 \cdot X_2 + P_{E4} l a_3^3 \cdot X_3 + P_{E4} r a_1^3 \cdot X_1 + P_{E4}^3 \cdot X_2 + P_{E4} r a_3^3 \cdot X_3)}{2l_s}}$$

$$= 1872.6 \text{ N}$$

5 Calculation of nominal life (L_n)

Base on the equation of the nominal life, we assume the $f_w=1.5$ and the result is as below:

$$L_1 = \left(\frac{C}{f_w \cdot P_{m1}} \right)^3 \times 50 = 98600 \text{ km}$$

$$L_3 = \left(\frac{C}{f_w \cdot P_{m3}} \right)^3 \times 50 = 60000 \text{ km}$$

$$L_2 = \left(\frac{C}{f_w \cdot P_{m2}} \right)^3 \times 50 = 28700 \text{ km}$$

$$L_4 = \left(\frac{C}{f_w \cdot P_{m4}} \right)^3 \times 50 = 295800 \text{ km}$$

From these calculations and under the operating conditions specified as above, the 28700 km running distance as service life of carriage No.2 is obtained.

9. Installation Direction of Linear Guideway

The installation direction of linear guideway depends on machine structure and load direction. When oil lubrication is applied, the lubricant routing will be varied with different applications. Therefore, please specify the direction of installation when ordering.

Horizontal (Code : H)

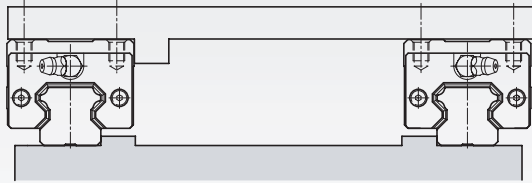

Vertical (Code : V)

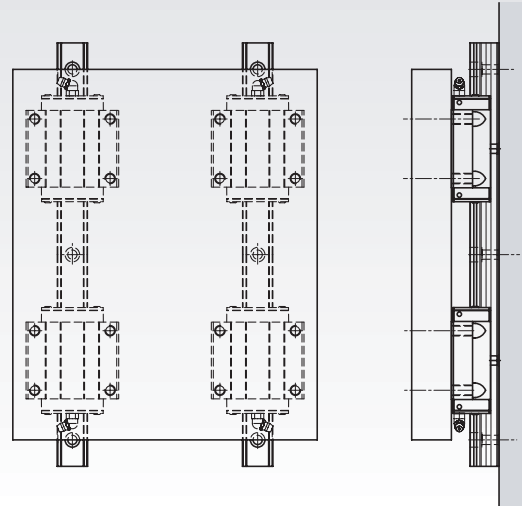

Inverted (Code : R)

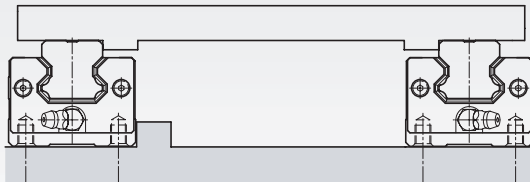

Opposed (Code : F)

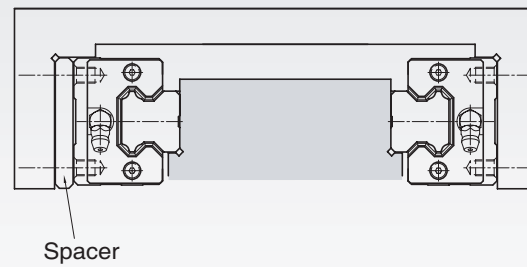

Wall mounting (Code : K)

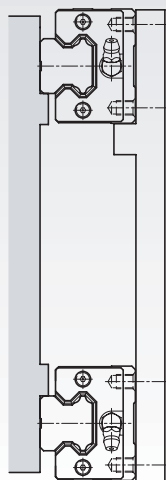

Tilted (Code : T)

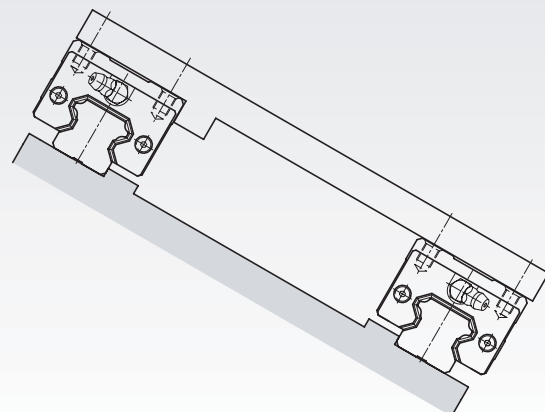

10. Fixing Methods of Linear Guideway

The rail and carriage could be displaced when machine receives vibration or impact. Under such situation, the running accuracy and service life will be degraded, so the following fixing methods are recommended for avoiding such situation happens.

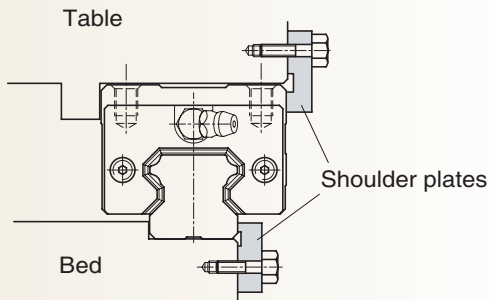

Shoulder plate(Recommended)

For this method, the rail and carriage should stick out slightly from the bed and table. To avoid interference from corner of carriage and rail, the shoulder plate should have a recess.

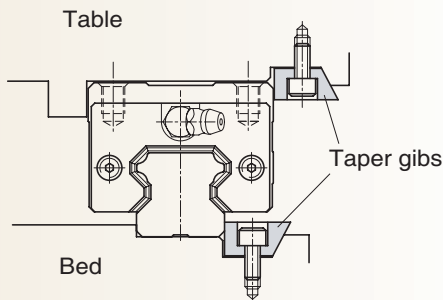

Taper gib

A slight tightening of the taper gib could generate a large pressing force to the linear guideway, and this may cause the rail to deform. Thus, this method should be carried with caution.

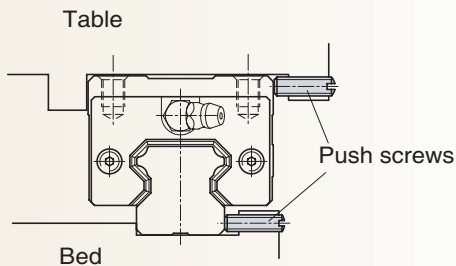

Push screw

Due to the limitation of installation space, the size of bolt should be thin.

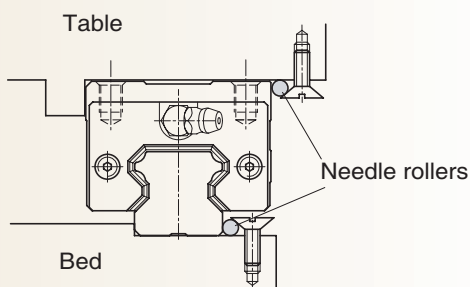

Needle roller

The needle roller is pressed by the taper section of the head of screw, so the position of screw should be paid attention.

11. Installation of Linear Guideway

11.1 Installation of Linear Guideway When Machine Subjected to Vibration and Impact

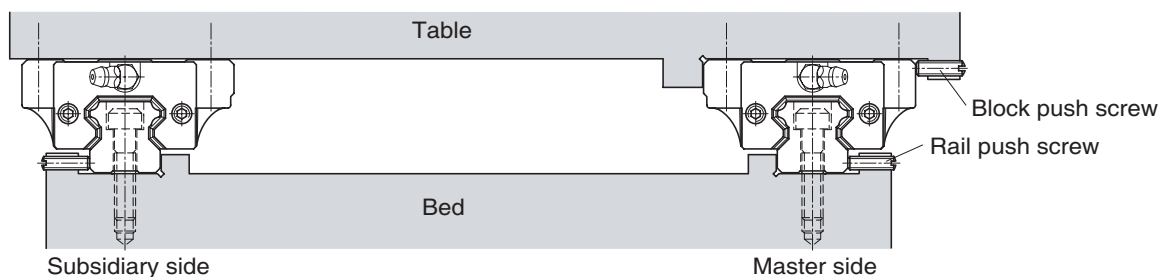

(1) Installation of rail

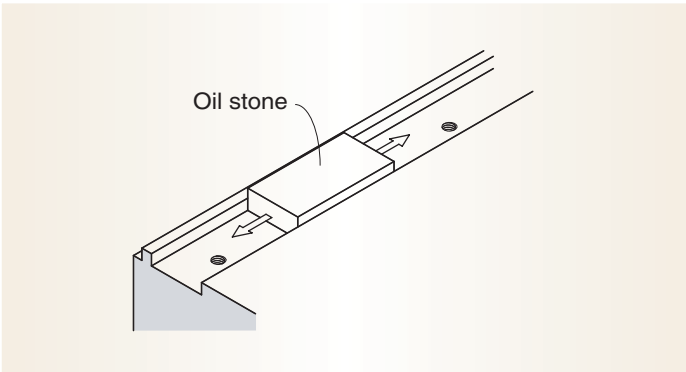

1. Prior to installation, the burrs, dirt, and rust preventive oil should be removed thoroughly.

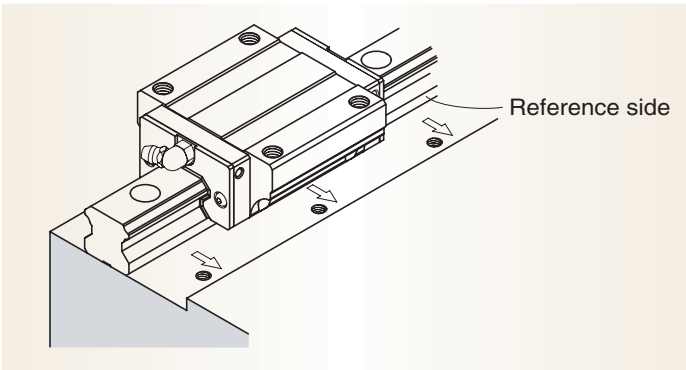

2. Gently place the linear guideway on the bed, and pushing it against the reference side of bed.

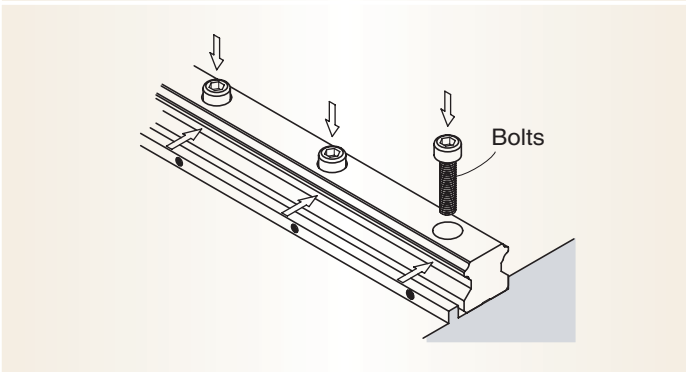

3. Check for correct bolt play and temporarily tighten all bolts.

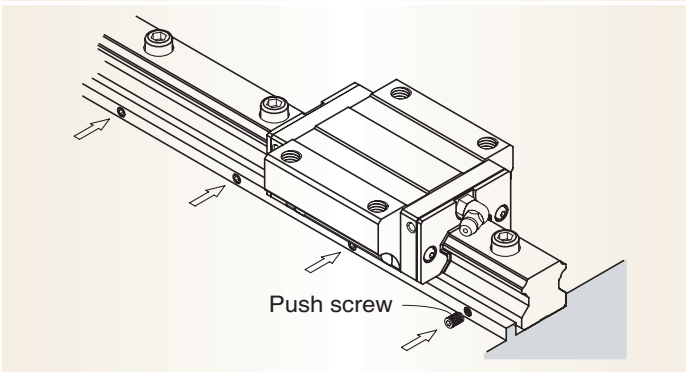

4. Tighten the push screw in sequence to ensure the rail close matching the reference side of bed.

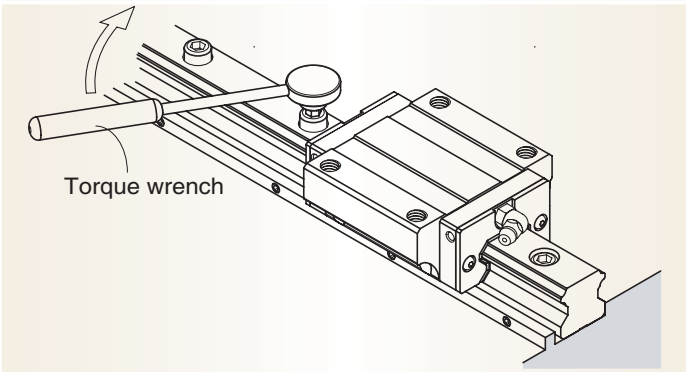

5. Tighten all bolts to the specified torque. The tightening sequence should start from the center to both ends. By doing this, the original accuracy could be achieved.

6. Follow the same procedure for the installation of remaining rails.

(2) Installation of carriage

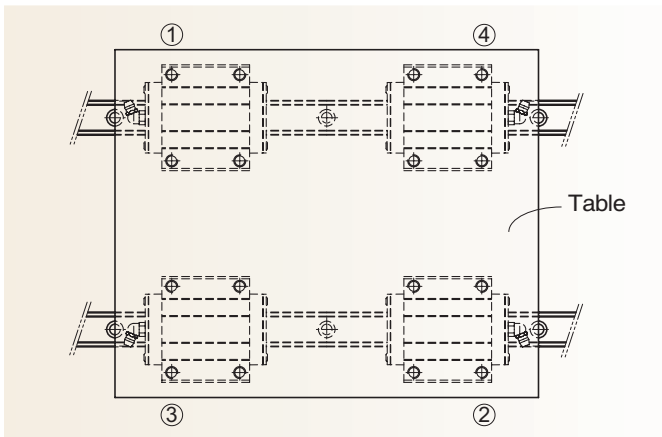

1. Gently place table onto carriages and temporarily tighten the bolts.
2. Tighten the push screw to hold the master rail carriage against the table reference side, and position the table.
3. Fully tighten all bolts on both master and subsidiary sides. The tightening process should be followed by the order of ① to ④.

11.2 Installation of Linear Guideway without Push Screws

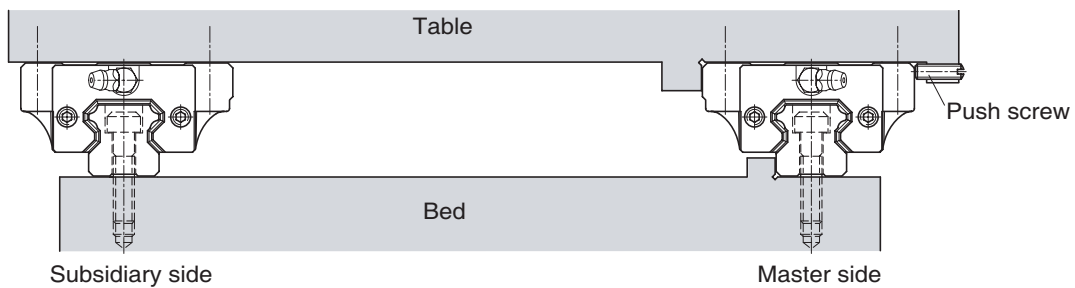

(1) Installation of master rail

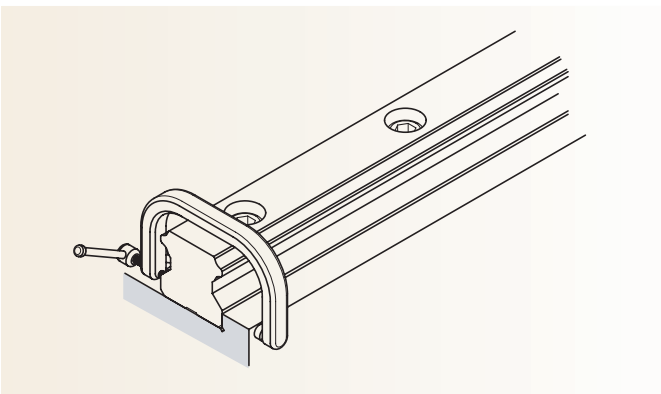

Using a vise

First tighten the mounting bolts temporarily, then use a C vise to press the master rail to reference side. Tighten the mounting bolts in sequence to specified torque.

(2) Installation of subsidiary rail

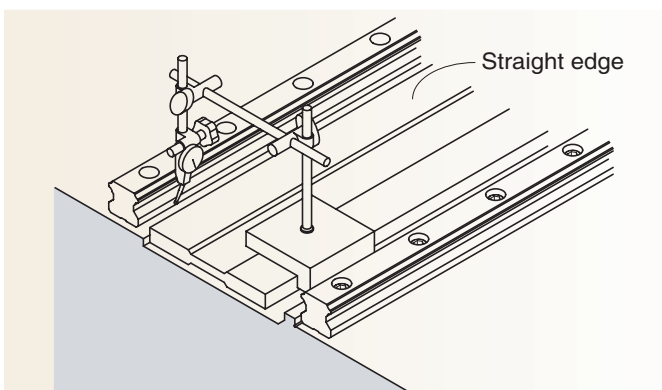

Using a straight edge

Place a straight edge between the two rails and position it parallel to the reference side rail which is temporarily tightened by bolts. Check the parallelism with dial gauge, and align the rail if necessary. Then tighten the bolts in sequence.

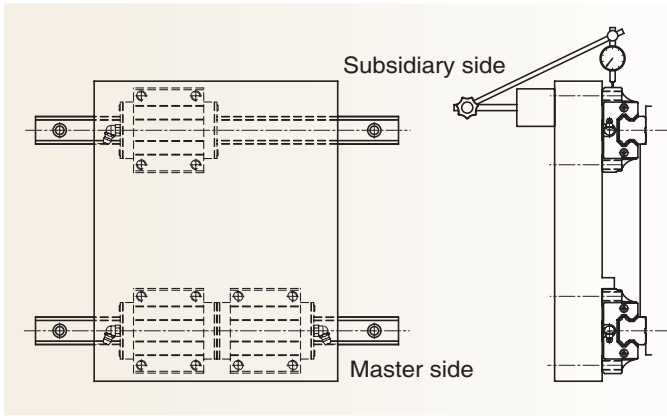

Using a table

Tighten two master side carriages and one subsidiary side carriage onto the table. Then temporarily tighten another subsidiary carriage and rail to the table and bed. Position a dial gauge on the table and have the probe of dial gauge contact the side of the subsidiary carriage. Move the table from the rail end and check the parallelism between the carriage and the subsidiary rail. Then tighten the bolts in sequence.

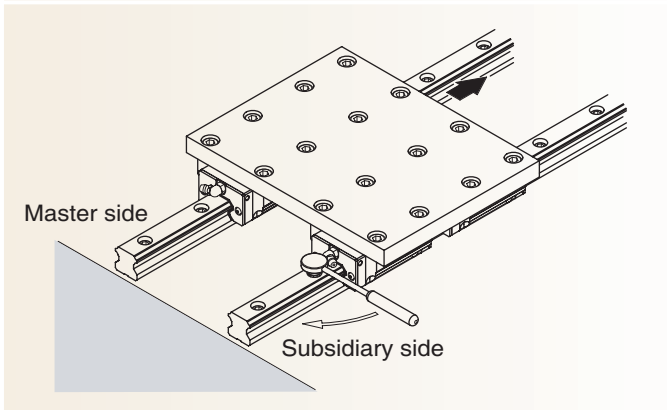

Compare to master rail side

Tighten two master side carriages and one subsidiary side carriage onto the table. Then temporarily tighten another subsidiary carriage and rail to the table and bed. Move the table from one rail, check and align the parallelism of subsidiary rail based on moving resistance. Tighten the bolts in sequence.

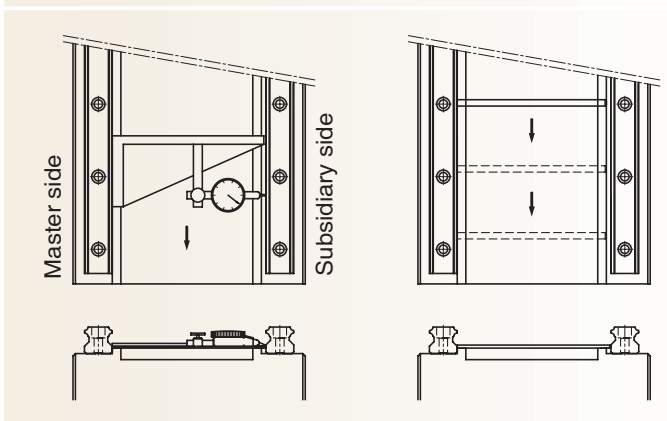

Using a jig

Using the special jig to align the parallelism between the reference side of master rail and that of subsidiary rail from one rail end to another. Tighten the mounting bolts in sequence.

(3) The installation of carriage follows the example described previously.

11.3 The Installation of Carriage of Linear Guideway without the Reference Side for Master Rail

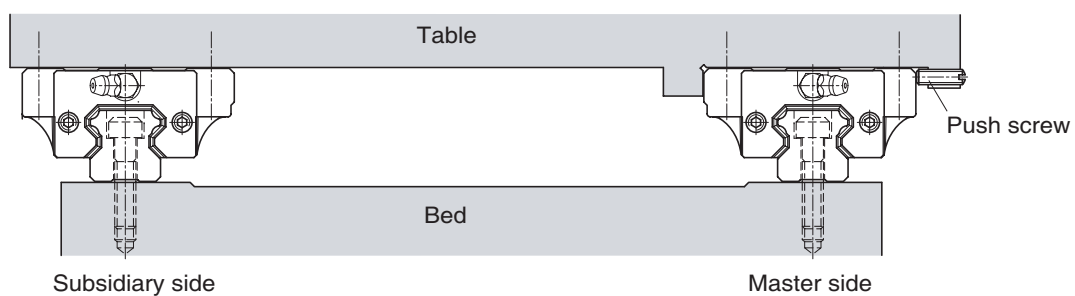

(1) Mounting the master rail

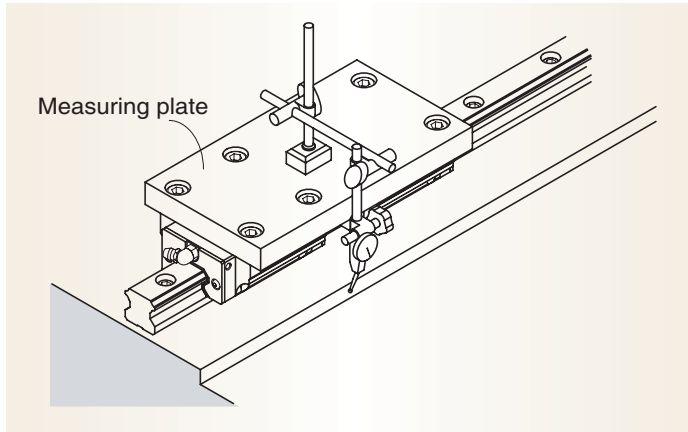

Using a temporary reference side

Two carriages are tightened together onto the measuring plate, and set up a temporary reference surface near the rail mounting surface on the bed. Check and align the parallelism of rails and then tighten bolts sequentially.

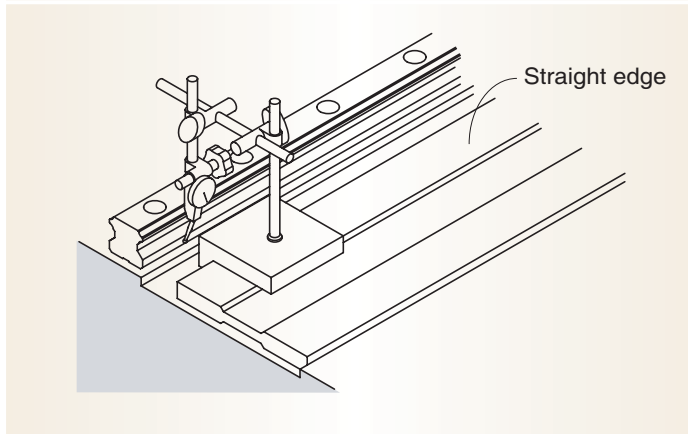

Using a straight edge

At first temporarily tighten rail onto the bed, then use a dial gauge to align the straightness of rail. Tighten the bolts in sequence.

(2) The installation of subsidiary carriage and rail is same as the prior examples.

11.4 Accuracy Measurement after Installation

The running accuracy can be obtained by tightening the two carriages onto the measuring plate. A dial gauge or autocollimeter is used for measuring the accuracy. If a dial gauge is used, the straight edge should be placed as close to carriage as possible for accurate measurement.

Measuring with an Autocollimeter

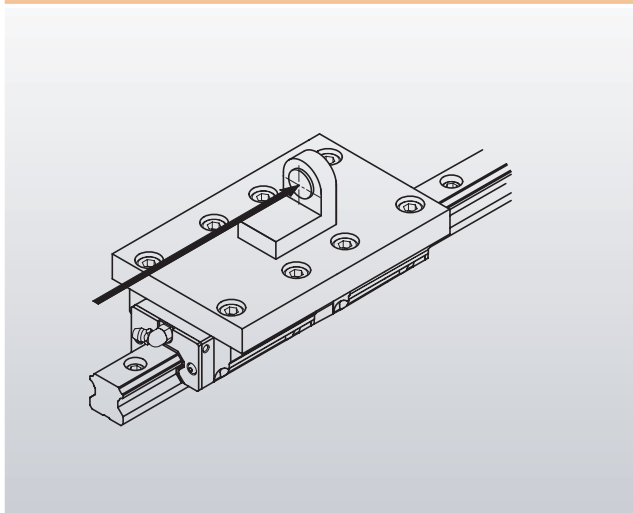

Measuring with a Dial Gauge

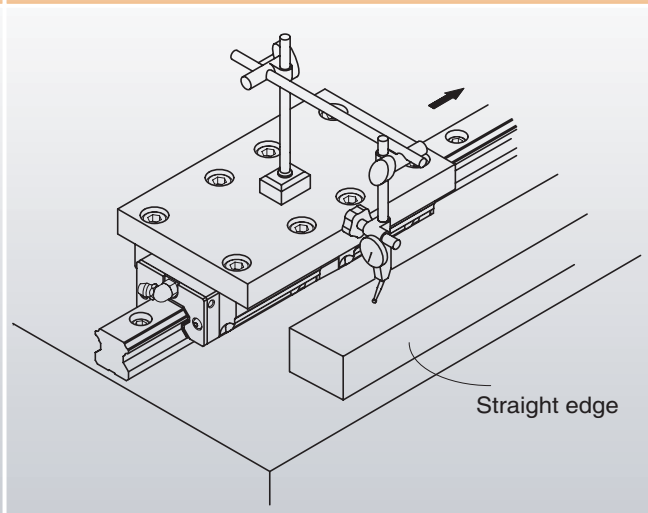

11.5 The Recommended Tightening Torque for Rails

The improper tightening torque could affect the mounting accuracy, so tightening the bolts by torque wrench to specified torque is highly recommended. Different types of mounting surface should have different torque value for applications.

Table 3 Tightening torque value

Unit : N·m

Bolt Model	Torque Value		
	Iron	Cast iron	Aluminum
M3	2	1.3	1
M4	4	2.7	2
M5	8.8	5.9	4.4
M6	13.7	9.2	6.8
M8	30	20	15
M10	68	45	33
M12	120	78	58
M14	157	105	78
M16	196	131	98
M20	382	255	191

* 1 N·m = 0.738 lbf·ft

12. Marking on Master Linear Guideway and Combined Case

12.1 Recognizing of Reference Side

The reference side of rail is assigned by the arrow sign which is marked together with the model code and lot number on top surface of rail while that of carriage is the side which is opposed to the side marked with lot number and model code marked, as shown on Fig. 5.

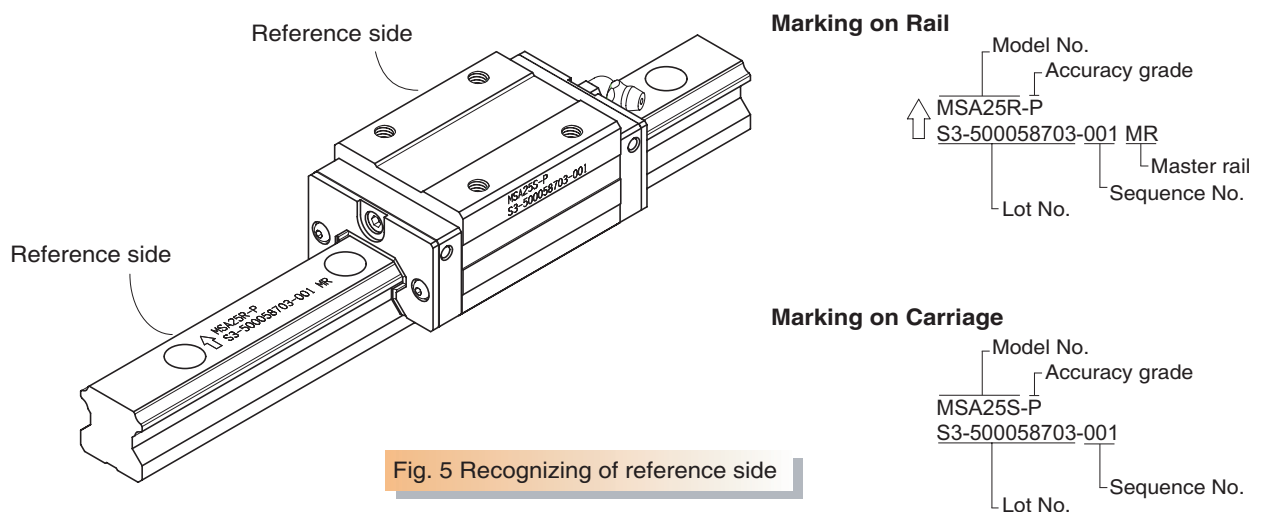

Fig. 5 Recognizing of reference side

12.2 Recognizing of Master Rail

Linear rails to be applied on the same plane are all marked with the same serial number, and "MR" is marked at the end of serial number for indicating the master rail, shown as Fig. 6. The reference side of carriage is the surface where is ground to a specified accuracy.

For normal grade (N), it has no mark "MR" on rail which means any one of rails with same serial number could be the master rail.

Fig. 6 Recognizing of master rail

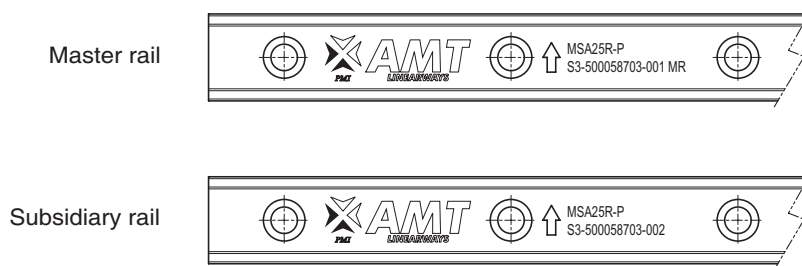

12.3 Combined Use of Rail and Carriage

For combined use, the rail and carriage must have the same serial number. When reinstalling the carriage back to the rail, make sure they have the same serial number and the reference side of carriage should be in accordance with that of rail.

12.4 For Butt-joint Rail

When applied length of rail longer than specified max. length, the rails can be connected to one another. For this situation, the joint marks indicate the matching position, as shown in Fig. 7.

Accuracy may deviate at joints when carriages pass the joint simultaneously. Therefore, the joints should be interlaced for avoiding such accuracy problem, as shown in Fig. 8.

Fig. 7 Identification of butt-joint rail

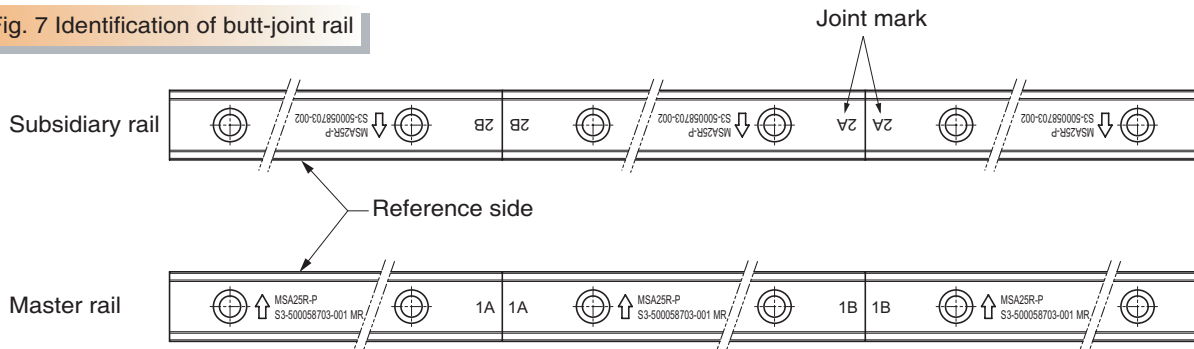
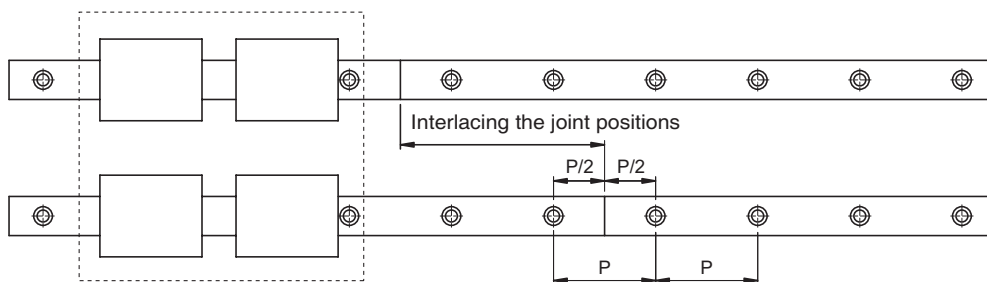

Fig. 8 Staggering the joint position



13. The Relationship between the Direction of Lubrication and the Reference Side

The standard lubrication fitting is grease nipple (G-M6 \ G-PT1/8 \ G-M4). The code of different types of application for lubrication fittings are shown in Table 4. For cases other than specified, please contact us for confirmation.

Table 4 The relationship between the direction of lubrication and the reference side

<p>Code: C1R1</p>	<p>Code: C1R2</p>
<p>Code: C2R1</p>	<p>Code: C2R2</p>
<p>Code: C3R1</p>	<p>Code: C3R2</p>
<p>Code: C4R1</p>	<p>Code: C4R2</p>

14. Accuracy Standard

The accuracy of linear guideway includes the dimensional tolerance of height, width, and the running accuracy of the carriage on the rail. The standard of the dimension difference is built for two or more carriages on a rail or a number of rails are used on the same plane.

The accuracy of linear guideway is divided into 5 classes, normal grade (N), high precision (H), precision (P), super precision (SP), and ultra precision (UP), as shown in Table 10 or 19.

Running parallelism

The running accuracy is the deviation of parallelism between the reference surface of carriage and reference surface of rail when carriage moving over the entire length of rail.

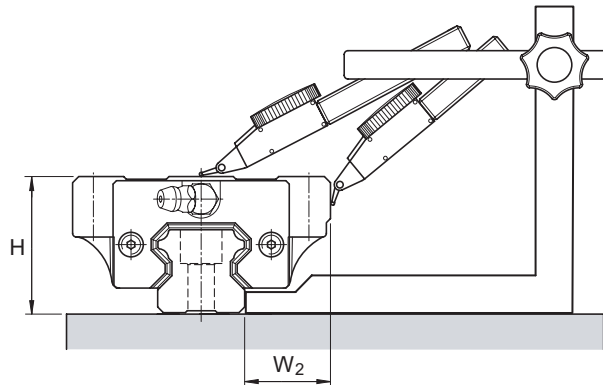

Fig. 9 Measuring the running parallelism

Height difference (ΔH)

The height difference (ΔH) means the height difference among carriages installed on the same plane.

Width difference (ΔW_2)

The width difference (ΔW_2) means the width difference among carriages installed on a rail.

Additional remarks

1. When two or more linear guideways are used on the same plane, the tolerance of W_2 and difference of ΔW_2 is applicable to master rail only.
2. The accuracy is measured at the center or central area of carriage.

15. The Selection of Accuracy Grade

The accuracy grade for different applications shown as Table 5.

Table 5 Accuracy grade for various applications

	Application	Accuracy Grade				
		N	H	P	SP	UP
Machine Tool	Machining center			●	●	
	Lathe			●	●	
	Milling machine			●	●	
	Boring machine			●	●	
	Jig borer				●	●
	Grinding machine				●	●
	Electric discharge machine			●	●	●
	Punching press		●	●		
	Laser-beam machine		●	●	●	
	Woodworking machine	●	●	●		
	NC drilling machine		●	●		
	Tapping center		●	●		
	Pallet changer	●				
	ATC	●				
	Wire cutter			●	●	
	Dresser				●	●

	Application	Accuracy Grade				
		N	H	P	SP	UP
Industrial Robot	Cartesian coordinate robot	●	●	●		
	Cylindrical coordinate robot	●	●			
Semiconductor Manufacturing	Wire bonder			●	●	
	Prober				●	●
	Electronic-component inserter		●	●		
	Printed-circuit-board drilling machine		●	●	●	
Others	Injection-molding machine	●	●			
	3D measuring instrument				●	●
	Office equipment	●	●			
	Transfer equipment	●	●			
	XY table		●	●	●	
	Painting machine	●	●			
	Welding machine	●	●			
	Medical equipment	●	●			
	Digitizer		●	●	●	
	Inspection equipment			●	●	●

16. Preload and Rigidity

The rigidity of a linear guideway could be enhanced by increasing the preload. As shown in Fig. 10, the load could be raised up to 2.8 times the preload applied. The preload is represented by negative clearance resulting from the increase of ball diameter. Therefore, the preload should be considered in calculation service life.

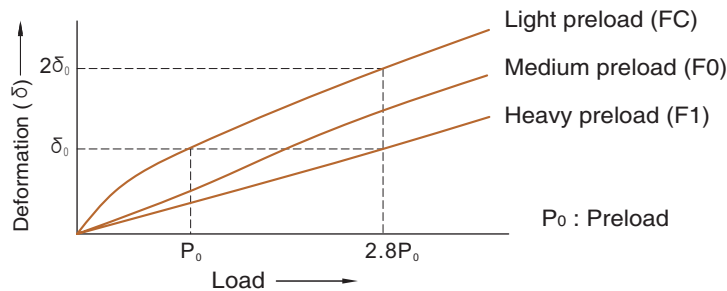

Fig.10 Rigidity

17. The Selection of Preload

Selecting proper preload from Table 6 to adapt the specific application and condition.

Table 6 Preload grade for various applications

Preload	Operating Condition	Major Application
Light preload (FC)	<ul style="list-style-type: none"> The loading direction is fixed, vibration and impact are light, and two axes are applied in parallel. High precision is not required, and the low frictional resistance is needed. 	Welding machine, binding machine, auto packing machine, x, y axis of ordinary industrial machine, material handling equipments.
Medium preload (F0)	<ul style="list-style-type: none"> Overhang application with a moment load. Applied in one-axis configuration The need of light preload and high precision. 	Z axis of industrial machines, EDM, precision x y table, PC board drilling machine, industrial robot, NC lathe, measuring equipment, grinding machine, auto painting machine.
Heavy preload (F1)	<ul style="list-style-type: none"> Machine is subjected to vibration and impact, and high rigidity required. Application of heavy load or heavy cutting. 	Machine center, NC lathe, grinding machine, milling machine, Z axis of boring machine and machine tools.

18. Lubrication

A well lubrication is important for maintaining the function of linear guideway. If the lubrication is not sufficient, the frictional resistance at rolling area will increase and the service life will be shortened as a result of wear of rolling parts.

Two primary lubricants are both grease and oil used for linear motion system, and the lubrication methods are categorized into manual and forced oiling. The selection of lubricant and its method should be based on the consideration of operating speed and environment requirement.

(1) Grease lubrication

The grease feeding interval will be varied with different operating conditions and environments. Under normal operating condition, the grease should be replenished every 100km of travel. The amount of grease for each type of carriage is shown as Table 7.

The standard grease for the MSA and MSB series is lithium-based grease No.2.

Table 7 Grease amount to be fed

Model No.	Initial Feeding Amount (cm ³)	Amount for Replenishing (cm ³)
MSA 15	0.4 (x 3)*	0.4
MSA 20	0.8 (x 3)*	0.8
MSA 25	1.0 (x 3)*	1.0
MSA 30	1.6 (x 3)*	1.6
MSA 35	2.5 (x 3)*	2.5
MSA 45	4.3 (x 3)*	4.3
MSA 55	7.8 (x 3)*	7.8
MSA 65	16 (x 3)*	16

Model No.	Initial Feeding Amount (cm ³)	Amount for Replenishing (cm ³)
MSB 15	0.4 (x 3)*	0.4
MSB 20	0.5 (x 3)*	0.5
MSB 25	0.8 (x 3)*	0.8
MSB 30	1.0 (x 3)*	1.0
MSB 35	3.0 (x 3)*	3.0

* The recommended initial feeding amount of grease is 3 times of the listed feeding amount. Moving the carriage back and forth with minimum stroke length of length of 3 carriages after the carriages been greased. To assure the grease is evenly distributed inside of carriage, the mentioned process should be repeated twice at least.

(2) Oil lubrication

The recommended viscosity of oil is 30~150 cst, and the recommended feeding rate per hour is shown as Table 8. The installation other than horizontal may caused the oil unable to reach raceway area, so please specify the installed direction your linear guideway applied. Reference is shown in Page 16.

Table 8 Oil lubrication feeding rate

Model No.	Initial Feeding Amount (cm ³)	Feeding Rate (cm ³ /hr)
MSA 15	0.2	0.2
MSA 20	0.4	0.2
MSA 25	0.5	0.3
MSA 30	0.8	0.3
MSA 35	1.2	0.3
MSA 45	2.2	0.4
MSA 55	3.6	0.5
MSA 65	6.0	0.6

Model No.	Initial Feeding Amount (cm ³)	Feeding Rate (cm ³ /hr)
MSB 15	0.2	0.2
MSB 20	0.3	0.2
MSB 25	0.5	0.3
MSB 30	0.6	0.3
MSB 35	1.2	0.3

Note:

When the operating stroke length less than the sum of length of two carriages, the lubrication fitting should be applied on both ends of carriage for adequacy. Moreover, if the stroke length less than a half of the length of a carriage, the carriage should be moved back and forth up to the length of two carriages while lubricating.

(3) Types of grease nipple and piping joint are shown as below:

Grease nipple

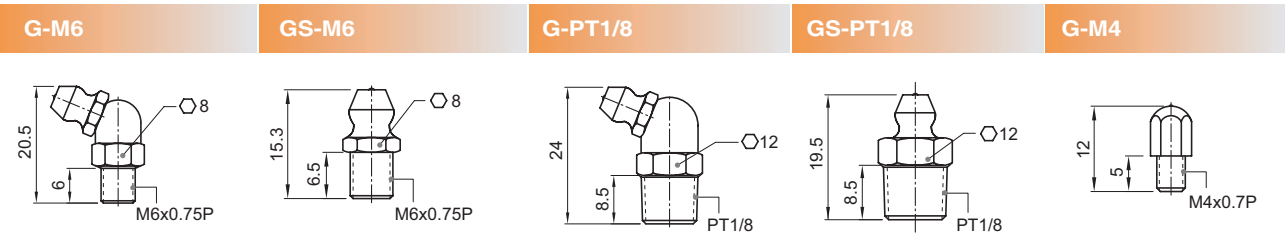

Oil piping joint

OL type

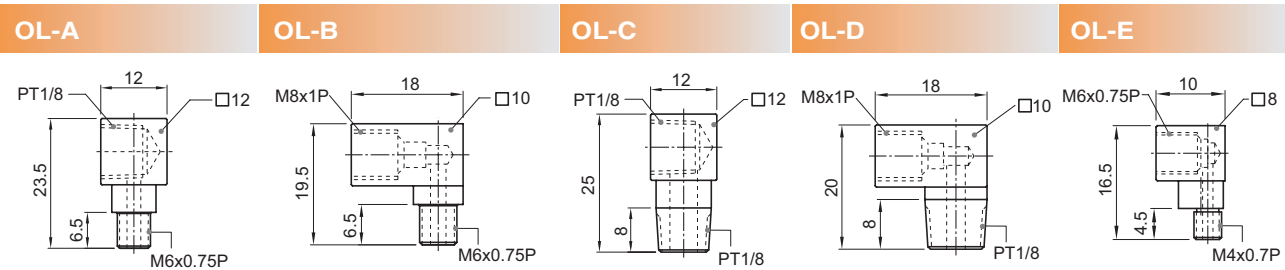

OS type

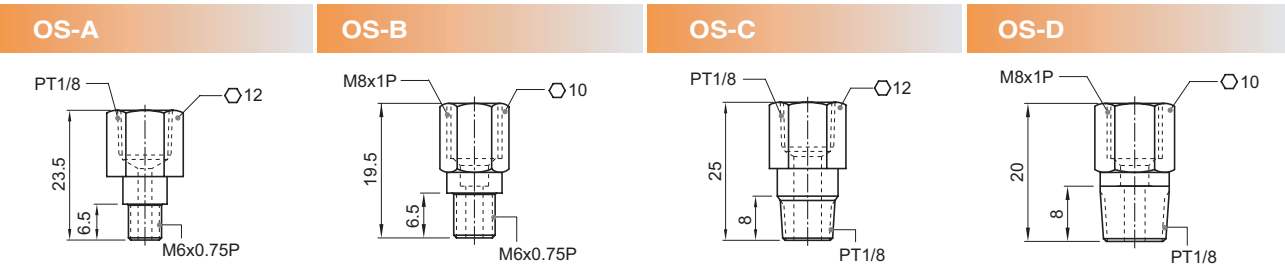

Model No.	Grease Nipple		Piping Joint			
	Standard	Option	Option			
MSA 15 MSB 15	G-M4	-	OL-E			
MSA 20 MSB 20	G-M6	GS-M6	OL-A	OL-B	OS-A	OS-B
MSA 25 MSB 25						
MSA 30 MSB 30						
MSA 35 MSB 35						
MSA 45	G-PT1/8	GS-PT1/8	OL-C	OL-D	OS-C	OS-D
MSA 55						
MSA 65						

(4) Lubrication position

The standard mounting locating of carriage is at the center of both ends, see Fig. 11. As for lateral application, please specify when ordering.

As shown as Fig. 12, the lateral application is achieved by using an adapter to connect the grease/oil fitting to the hole on the carriage.

Fig. 11 Lubrication location

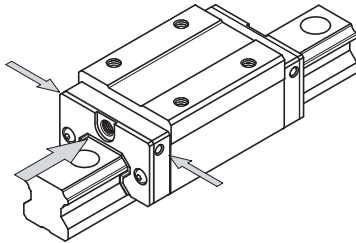
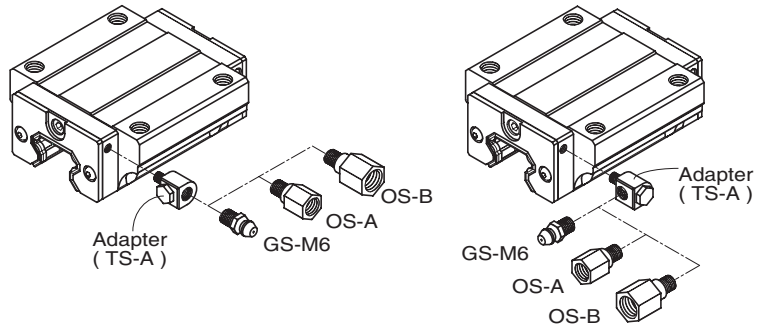

Fig. 12 Lateral usage



19. Plastic Caps for rail mounting hole

A special designed of cap is used to cover the bolt hole to prevent the foreign matters from entering the carriage. The cap is mounted by using a plastic hammer with a flat pad placed on the top, until the top of cap is flush to the top surface of rail. See Fig. 13.

The dimension of caps for different sizes of rail is shown as Table 9.

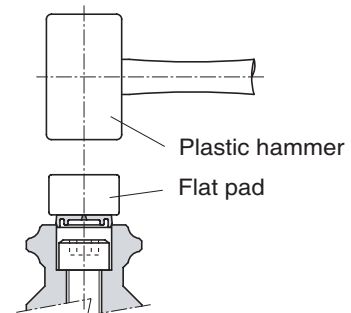
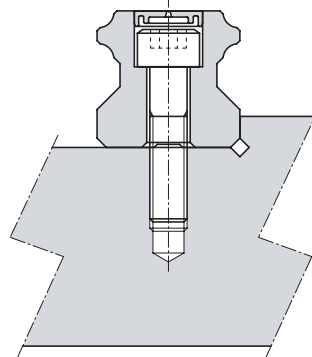
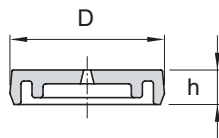

Fig.13 Plastic cap for rail mounting hole

Installation method

Table 9 Dimensions of plastic caps

Code of Cap	Bolt Size	D(mm)	h(mm)	Rail Model
M3C	M3	6.3	1.1	MSB15R
M4C	M4	7.8	1.1	MSA15R MSB15U
M5C	M5	9.8	2.2	MSA20R MSB20R
M6C	M6	11.3	2.5	MSA25R MSB25R MSB30R
M8C	M8	14.4	3.3	MSA30R MSA35R MSB35R
M12C	M12	20.4	4.6	MSA45R
M14C	M14	23.4	5	MSA55R
M16C	M16	26.4	5	MSA65R

20. Construction and Characteristics of MSA and MSB Series

Construction

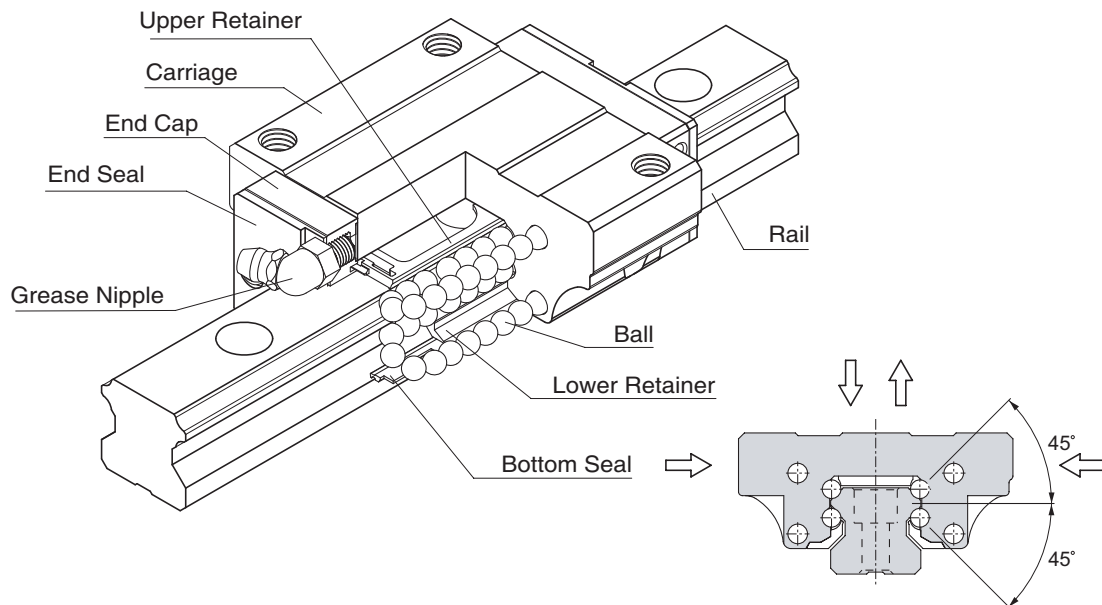

Characteristics

The trains of balls are designed to a contact angle of 45° which enables it to bear an equal load in radial, reversed radial and lateral directions. Therefore, it can be applied in any installation direction. Furthermore, MSA and MSB series can achieve a well balanced preload for increasing rigidity in four directions while keeping a low frictional resistance. This is especially suit to high precision and high rigidity required motion.

The patent design of lubrication route makes the lubricant evenly distribute in each circulation loop. Therefore, the optimum lubrication can be achieved in any installation direction, and this promotes the performance in running accuracy, service life, and reliability.

High Rigidity, Four-way Equal Load

The four trains of balls are allocated to a circular contact angle at 45° , thus each train of balls can take up an equal rated load in all four directions. Moreover, a sufficient preload can be achieved to increase rigidity, and this makes it suitable for any kind of installation.

Self Alignment Capability

The self adjustment is performed spontaneously as the design of face-to-face (DF) circular arc groove. Therefore, the installation error could be compensated even under a preload, and which results in precise and smooth linear motion.

Smooth Movement with Low Noise

The simplified design of circulating system with strengthened synthetic resin accessories makes the movement smooth and quiet.

Interchangeability

For interchangeable type of linear guideway, the dimensional tolerances are strictly maintained within a reasonable range, and this has made the random matching of the same size of rails and carriages possible. Therefore, the similar preload and accuracy can be obtained even under the random matching condition, As a result of this advantage, the linear guideway can be stocked as standard parts, the installation and maintenance become more convenient. Moreover, this is also beneficial for shortening the delivery time.

21. MSA Series - Heavy Load Type

21.1 Carriage Type

Heavy Load

MSA-A Type

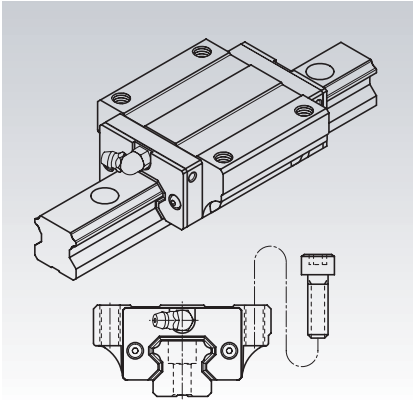

Installed from top side of carriage with the thread length longer than MSA-E type.

MSA-E Type

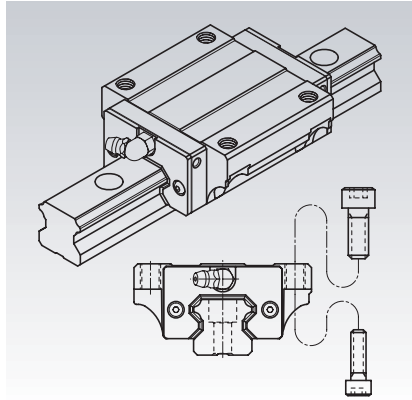

This type offers the installation either from top or bottom side of carriage.

MSA-S Type

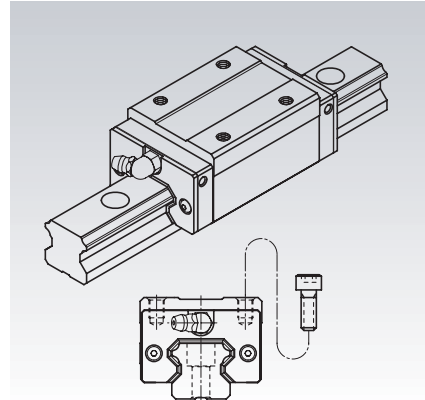

Square type with smaller width and can be installed from top side of carriage.

Ultra Heavy Load

MSA-LA Type

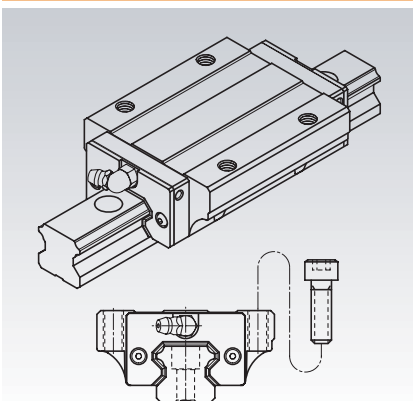

All dimensions are same as MSA-A except the length is longer, which makes it more rigid.

MSA-LE Type

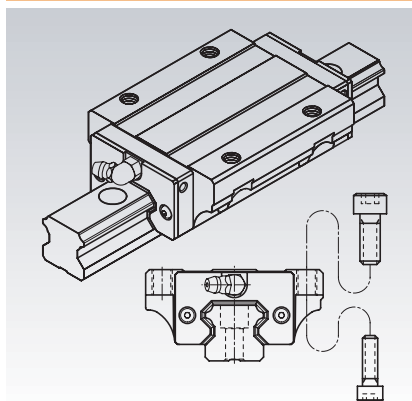

All dimensions are same as MSA-E except the length is longer, which makes it more rigid.

MSA-LS Type

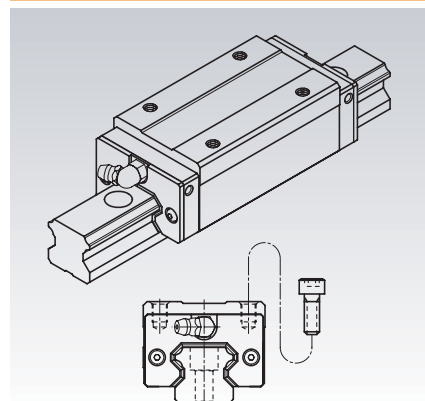

All dimensions are same as MSA-S except the length is longer, which makes it more rigid.

21.2 Rail Type

Counter-bore (R type)

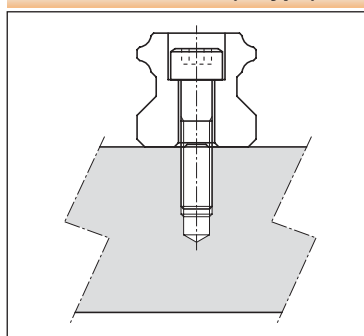

Tapped Hole (T type)

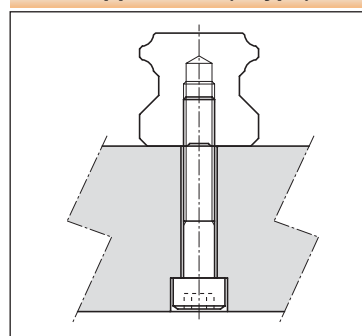

21.3 Description of Specification

(1) Non-Interchangeable Type

	MSA	25	A	2	SS	F0	A	+ R	1200	-20	/ 40	P	A	II
Series : MSA														
Size : 15, 20, 25, 30, 35, 45, 55, 65														
Carriage type : (1) Heavy load A : Flange type, mounting from top E : Flange type, mounting either from top or bottom S : Square type (2) Ultra heavy load LA : Flange type, mounting from top LE : Flange type, mounting either from top or bottom LS : Square type														
Number of carriages per rail : 1, 2, 3 ...														
Dust protection option : No symbol, UU, SS, ZZ, DD, KK, LL, RR														
Preload : FC (Light preload) , F0 (Medium preload) , F1 (Heavy preload)														
Code of special carriage : No symbol, A, B ...														
Rail type : R (Counter-bore type) , T (Tapped hole type)														
Rail length (mm)														
Rail hole pitch from start side (E1 , see Fig.14)														
Rail hole pitch to the end side (E2 , see Fig.14)														
Accuracy grade : N, H, P, SP, UP														
Code of special rail : No symbol, A, B ...														
Number of rails per axis : No symbol , II, III, IV ...														

Fig.14

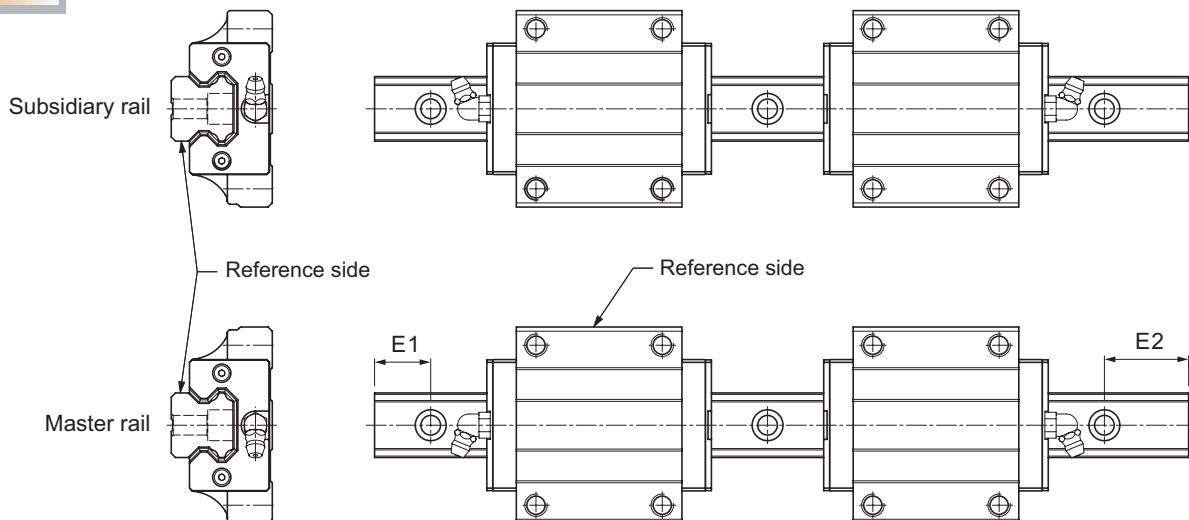

(2) Interchangeable Type

Code of Carriage

	MSA	25	A	SS	FC	N	A
Series : MSA							
Size : 15, 20, 25, 30, 35, 45, 55, 65							
Carriage type : (1) Heavy load A : Flange type, mounting from top E : Flange type, mounting either from top or bottom S : Square type (2) Ultra heavy load LA : Flange type, mounting from top LE : Flange type, mounting either from top or bottom LS : Square type							
Dust protection option : No symbol, UU, SS, ZZ, DD, KK, LL, RR							
Preload : FC (Light preload)							
Accuracy grade : N, H							
Code of special carriage : No symbol, A, B ...							

Code of Rail

	MSA	25	R	1200	- 20	/ 40	N	A
Series : MSA								
Size : 15, 20, 25, 30, 35, 45, 55, 65								
Rail Type : R (Counter-bore type), T (Tapped hole type)								
Rail length (mm)								
Rail hole pitch from start side (E1 , see Fig.14)								
Rail hole pitch to the end side (E2 , see Fig.14)								
Accuracy grade : N, H								
Code of special rail : No symbol, A, B ...								

21.4 Accuracy Grade

The accuracy of MSA series is divided into 5 classes, normal grade (N), high precision (H), precision (P), super precision (SP), and ultra precision (UP), as shown in Table 10.

Table 10 Accuracy Grade

Unit : mm

Model No.	Item	Accuracy Grade				
		Normal N	High H	Precision P	Super Precision SP	Ultra Precision UP
MSA 15 MSA 20	Tolerance for height H	± 0.1	± 0.03	$\begin{matrix} 0 \\ -0.03 \end{matrix}$	$\begin{matrix} 0 \\ -0.015 \end{matrix}$	$\begin{matrix} 0 \\ -0.008 \end{matrix}$
	Height difference ΔH	0.02	0.01	0.006	0.004	0.003
	Tolerance for distance W_2	± 0.1	± 0.03	$\begin{matrix} 0 \\ -0.03 \end{matrix}$	$\begin{matrix} 0 \\ -0.015 \end{matrix}$	$\begin{matrix} 0 \\ -0.008 \end{matrix}$
	Difference in distance $W_2 (\Delta W_2)$	0.02	0.01	0.006	0.004	0.003
	Running parallelism of surface C with surface A	ΔC (see Fig.15)				
	Running parallelism of surface D with surface B	ΔD (see Fig.15)				
MSA 25 MSA 30 MSA 35	Tolerance for height H	± 0.1	± 0.04	$\begin{matrix} 0 \\ -0.04 \end{matrix}$	$\begin{matrix} 0 \\ -0.02 \end{matrix}$	$\begin{matrix} 0 \\ -0.01 \end{matrix}$
	Height difference ΔH	0.02	0.015	0.007	0.005	0.003
	Tolerance for distance W_2	± 0.1	± 0.04	$\begin{matrix} 0 \\ -0.04 \end{matrix}$	$\begin{matrix} 0 \\ -0.02 \end{matrix}$	$\begin{matrix} 0 \\ -0.01 \end{matrix}$
	Difference in distance $W_2 (\Delta W_2)$	0.03	0.015	0.007	0.005	0.003
	Running parallelism of surface C with surface A	ΔC (see Fig.15)				
	Running parallelism of surface D with surface B	ΔD (see Fig.15)				
MSA 45 MSA 55	Tolerance for height H	± 0.1	± 0.05	$\begin{matrix} 0 \\ -0.05 \end{matrix}$	$\begin{matrix} 0 \\ -0.03 \end{matrix}$	$\begin{matrix} 0 \\ -0.02 \end{matrix}$
	Height difference ΔH	0.03	0.015	0.007	0.005	0.003
	Tolerance for distance W_2	± 0.1	± 0.05	$\begin{matrix} 0 \\ -0.05 \end{matrix}$	$\begin{matrix} 0 \\ -0.03 \end{matrix}$	$\begin{matrix} 0 \\ -0.02 \end{matrix}$
	Difference in distance $W_2 (\Delta W_2)$	0.03	0.02	0.01	0.007	0.005
	Running parallelism of surface C with surface A	ΔC (see Fig.15)				
	Running parallelism of surface D with surface B	ΔD (see Fig.15)				
MSA 65	Tolerance for height H	± 0.1	± 0.07	$\begin{matrix} 0 \\ -0.07 \end{matrix}$	$\begin{matrix} 0 \\ -0.05 \end{matrix}$	$\begin{matrix} 0 \\ -0.03 \end{matrix}$
	Height difference ΔH	0.03	0.02	0.01	0.007	0.005
	Tolerance for distance W_2	± 0.1	± 0.07	$\begin{matrix} 0 \\ -0.07 \end{matrix}$	$\begin{matrix} 0 \\ -0.05 \end{matrix}$	$\begin{matrix} 0 \\ -0.03 \end{matrix}$
	Difference in distance $W_2 (\Delta W_2)$	0.03	0.025	0.015	0.01	0.007
	Running parallelism of surface C with surface A	ΔC (see Fig.15)				
	Running parallelism of surface D with surface B	ΔD (see Fig.15)				

Fig.15 Running Parallelism of Carriage

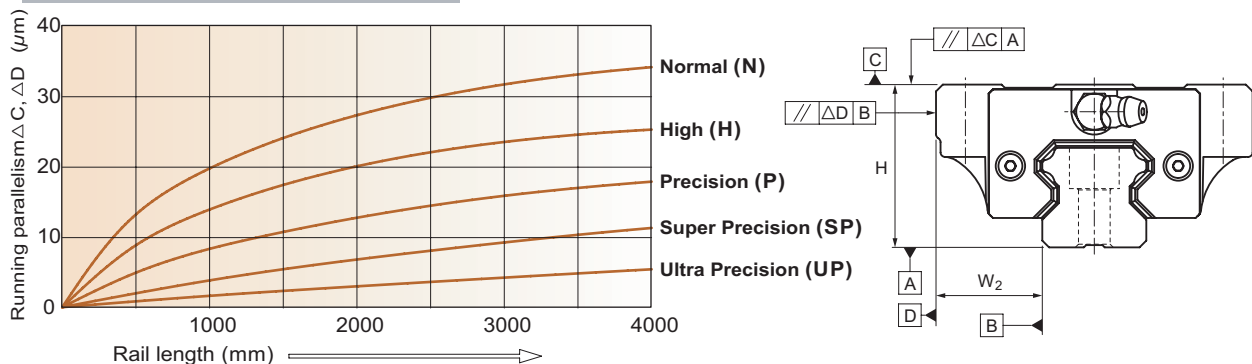

21.5 Preload Grade and Rigidity

(1) Preload grade

The preload of MSA series is represented by radial clearance which is divided into three grades, light (FC), medium (F0), heavy (F1), as shown in Table 11.

Table 11 Preload grade and radial clearance

Unit : m

Preload Model No.	Light	Medium	Heavy
	FC	F0	F1
MSA 15	-4 ~ +2	-12 ~ -4	-
MSA 20	-5 ~ +2	-14 ~ -5	-23 ~ -14
MSA 25	-6 ~ +3	-16 ~ -6	-26 ~ -16
MSA 30	-7 ~ +4	-19 ~ -7	-31 ~ -19
MSA 35	-8 ~ +4	-22 ~ -8	-35 ~ -22
MSA 45	-10 ~ +5	-25 ~ -10	-40 ~ -25
MSA 55	-12 ~ +5	-29 ~ -12	-46 ~ -29
MSA 65	-14 ~ +7	-32 ~ -14	-50 ~ -32

(2) Rigidity value

The rigidity values of preloaded linear guideway of MSA series are shown as Table 12.

Table 12 Rigidity value

	Model No.	Rigidity Value (N/ m)		
		Light preload FC	Medium preload F0	Heavy preload F1
Heavy Load Type	MSA15 A, E, S	222	321	-
	MSA20 A, E, S	262	429	507
	MSA25 A, E, S	309	491	575
	MSA30 A, E, S	347	615	718
	MSA35 A, E, S	399	702	822
	MSA45 A, E, S	518	892	1042
	MSA55 E, S	631	1077	1260
	MSA65 E, S	772	1363	1592
Ultra Heavy Load Type	MSA20 LA, LE, LS	343	595	697
	MSA25 LA, LE, LS	375	663	774
	MSA30 LA, LE, LS	455	803	938
	MSA35 LA, LE, LS	533	929	1087
	MSA45 LA, LE, LS	681	1170	1369
	MSA55 LE, LS	827	1414	1654
	MSA65 LE, LS	1031	1809	2117

21.6 Dust Proof

(1) Contamination protection

MSA series of linear guideway offers various kinds of dust protection accessory to keep the foreign matters from entering into the carriage.

End seal

Two types sealing are available:

1. Bidirectional seal for high dust protection required.
2. Monodirectional seal for low frictional resistance required.

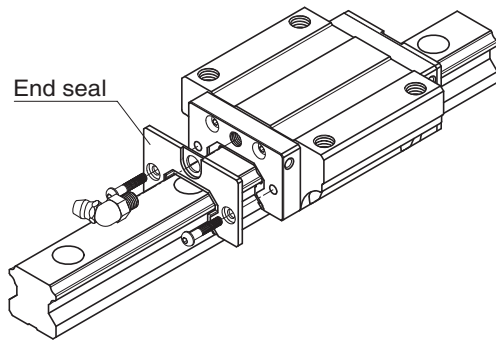

Bottom seal

Preventing the inclusion of foreign matters from bottom of carriage.

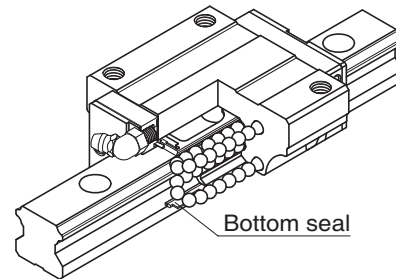

Double end seal

For enhancing the dust protection.

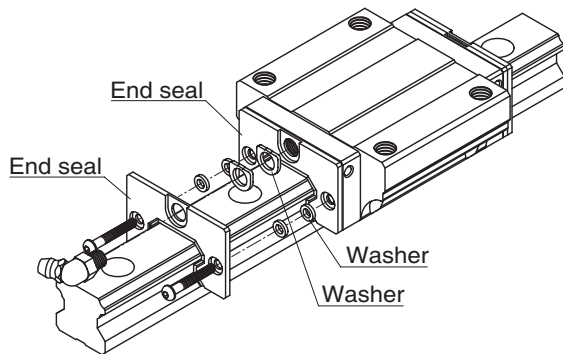

Metallic scraper

Removing spatters, iron chips, and large foreign matters as well as protecting the end seals.

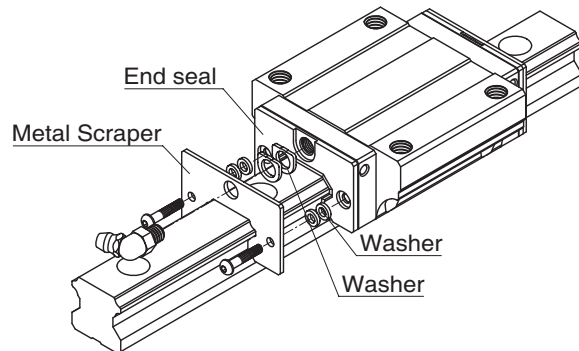

(2) Code of contamination protection

The codes for selection of dust protection accessory are shown as Table 13.

The increment to be added to the length of carriage with different applications of dust protection accessory is shown as Table 14.

Table 13 Code of contamination protection

Code	Contamination Protection
No symbol	Scraper (both ends)
UU	Bidirectional end seal (both ends)
SS	Bidirectional end seal + Bottom seal
ZZ	SS + Scraper
DD	Double bidirectional end seal + Bottom seal
KK	DD + Scraper
LL	Low frictional end seal
RR	LL + Bottom seal

Table 14 Types of seal to the increment to the carriage overall length

Unit : mm

Model No.	No symbol	UU	SS	LL	RR	ZZ	DD	KK
MSA 15	1	-	-	-	-	6	5	11
MSA 20	1.4	-	-	-	-	7	5.6	12.6
MSA 25	1.4	-	-	-	-	7	5.6	12.6
MSA 30	1.4	-	-	-	-	7	5.6	12.6
MSA 35	0.6	-	-	-	-	7.8	7.2	15
MSA 45	0.6	-	-	-	-	7.8	7.2	15
MSA 55	0.6	-	-	-	-	7.8	7.2	15
MSA 65	0.6	-	-	-	-	7.8	7.2	15

(3) Resistance value of seal

The maximum resistance value of seals type UU when it is applied with grease is shown as Table 15.

Table 15 Seal resistance value

Unit : N

Model No.	Resistance
MSA 15	2
MSA 20	3.5
MSA 25	4
MSA 30	6
MSA 35	10
MSA 45	12
MSA 55	18
MSA 65	30

21.7 The Shoulder Height and Corner Radius for Installation

The mounting surface of rails and carriages are machined precisely for aiding in positioning and assemble with high accuracy. The shoulder height and corner radius providing enough mounting space for not to interfere with chamfers made on rails and carriages.

The dimensions of shoulder height and corner radius are shown as Table 16.

Table 16 Shoulder height and corner radius of mounting surface

Unit : mm

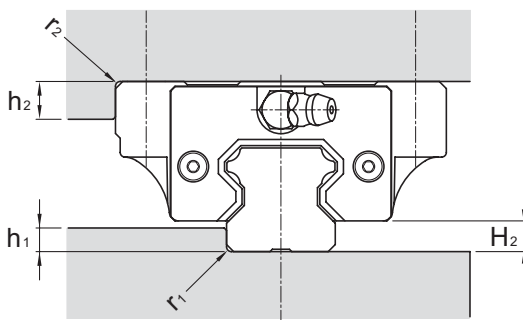

Model No.	r_1 (max.)	r_2 (max.)	h_1	h_2	H_2
MSA 15	0.5	0.5	3	4	4.2
MSA 20	0.5	0.5	3.5	5	5
MSA 25	1	1	5	5	6.5
MSA 30	1	1	5	5	8
MSA 35	1	1	6	6	9.5
MSA 45	1	1	8	8	10
MSA 55	1.5	1.5	10	10	13
MSA 65	1.5	1.5	10	10	15

21.8 Dimensional Tolerance of Mounting Surface

Thanks to the self alignment capability of MSA series, the minor dimensional error in mounting surface could be compensated and achieves smooth linear motion. The tolerances of parallelism between two axes are shown as below.

The parallel deviation between two axes (e_1)

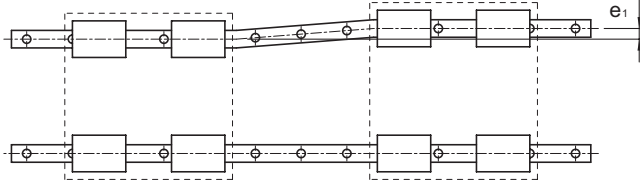

Table 17 Parallel deviation (e_1)

Unit : m

Model No.	Preload Grade		
	FC	F0	F1
MSA 15	25	18	-
MSA 20	25	20	18
MSA 25	30	22	20
MSA 30	40	30	27
MSA 35	50	35	30
MSA 45	60	40	35
MSA 55	70	50	45
MSA 65	80	60	55

Level difference between two axes (e_2)

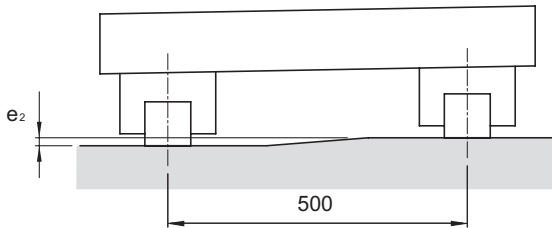

Table 18 Level difference between two axes (e_2)

Unit : m

Model No.	Preload Grade		
	FC	F0	F1
MSA 15	130	85	-
MSA 20	130	85	50
MSA 25	130	85	70
MSA 30	170	110	90
MSA 35	210	150	120
MSA 45	250	170	140
MSA 55	300	210	170
MSA 65	350	250	200

Note: The permissible values in table are applicable when the span is 500mm wide.

21.9 Tapped-hole Rail Dimensions

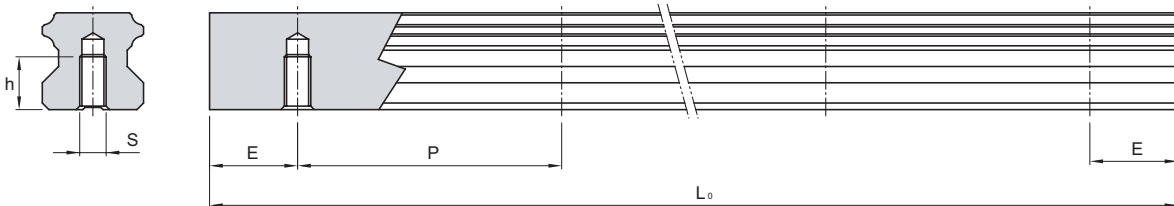

Rail Size	S	h(mm)
MSA 15 T	M5	8
MSA 20 T	M6	10
MSA 25 T	M6	12
MSA 30 T	M8	15
MSA 35 T	M8	17
MSA 45 T	M12	24
MSA 55 T	M14	24
MSA 65 T	M20	30

21.10 Rail Standard and Maximum Length

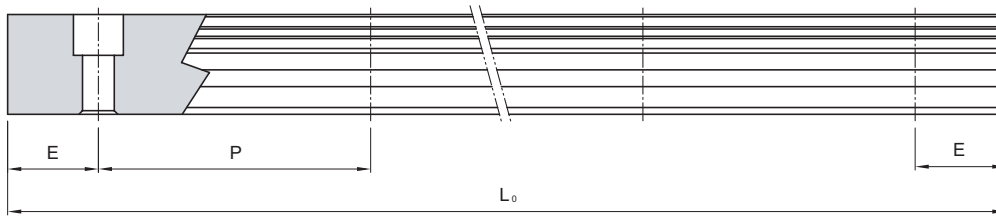

Unit : mm

Model No.	MSA 15	MSA 20	MSA 25	MSA 30	MSA 35	MSA 45	MSA 55	MSA 65
	160	220	220	280	280	570	780	1270
	220	280	280	360	360	675	900	1420
	280	340	340	440	440	780	1020	1570
	340	400	400	520	520	885	1140	1720
	400	460	460	600	600	990	1260	1870
	460	520	520	680	680	1095	1380	2020
	520	580	580	760	760	1200	1500	2170
	580	640	640	840	840	1305	1620	2320
	640	700	700	920	920	1410	1740	2470
	700	760	760	1000	1000	1515	1860	2620
	760	820	820	1080	1080	1620	1980	2770
	820	880	880	1160	1160	1725	2100	2920
	880	940	940	1240	1240	1830	2220	3070
	940	1000	1000	1320	1320	1935	2340	3220
	1000	1060	1060	1400	1400	2040	2460	3370
	1060	1120	1120	1480	1480	2145	2580	3520
	1120	1180	1180	1560	1560	2250	2700	3670
	1180	1240	1240	1640	1640	2355	2820	3820
	1240	1300	1300	1720	1720	2460	2940	3970
	1300	1360	1360	1800	1800	2565	3060	
	1360	1420	1420	1880	1880	2670	3180	
	1420	1480	1480	1960	1960	2775	3300	
	1480	1540	1540	2040	2040	2880	3420	
	1540	1600	1600	2120	2120	2985	3540	
	1600	1660	1660	2200	2200	3090	3660	
	1660	1720	1720	2280	2280	3195	3780	
	1720	1780	1780	2360	2360	3300	3900	
	1780	1840	1840	2440	2440	3390		
	1900	1900	1900	2520	2520			
	1960	1960	1960	2600	2600			
	2020	2020	2020	2680	2680			
	2080	2080	2080	2760	2760			
	2140	2140	2140	2840	2840			
	2200	2200	2200	2920	2920			
	2260	2260	2260	3000	3000			
	2320	2320	2320	3080	3080			
	2380	2380	2380	3160	3160			
	2440	2440	2440	3240	3240			
	2500	2500	2500	3320	3320			
	2560	2560	2560	3400	3400			
	2620	2620	2620	3480	3480			
	2680	2680	2680	3560	3560			
	2740	2740	2740	3640	3640			
	2980	2800	2800	3960	3960			
			2860					
			2920					
			2980					
			3040					
			3100					
			3160					
			3220					
			3280					
			3340					
			3400					
			3460					
			3520					
			3580					
			3640					
			3700					
			3760					
			4000					
Standard Pitch (P)	60	60	60	80	80	105	120	150
Standard E	20	20	20	20	20	22.5	30	35
Minimum E	5	6	7	8	8	11	13	14
Max. Length L ₀	2000	3000	4000	4000	4000	4000	4000	4000

21.11 Dimensions of MSA-A / MSA-LA

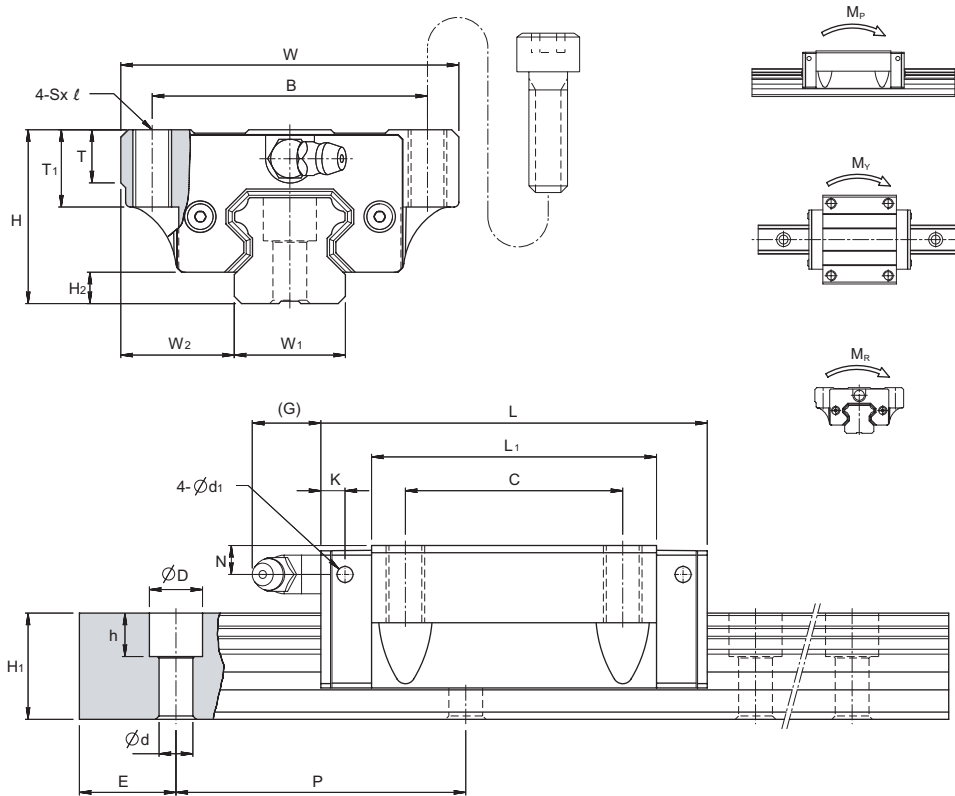

Unit : mm

Model No.	External dimension					Carriage dimension											Grease Nipple
	Height H	Width W	Length L	W ₂	H ₂	B	C	Sxℓ	L ₁	T	T ₁	N	G	K	d ₁		
MSA 15 A	24	47	56.3	16	4.2	38	30	M5x11	39.3	7	11	4.3	7	3.2	3.3	G-M4	
MSA 20 A MSA 20 LA	30	63	72.9 88.8	21.5	5	53	40	M6x10	51.3 67.2	7	10	5	12	5.8	3.3	G-M6	
MSA 25 A MSA 25 LA	36	70	81.6 100.6	23.5	6.5	57	45	M8x16	59 78	11	16	6	12	5.8	3.3	G-M6	
MSA 30 A MSA 30 LA	42	90	97 119.2	31	8	72	52	M10x18	71.4 93.6	11	18	7	12	6.5	3.3	G-M6	
MSA 35 A MSA 35 LA	48	100	111.2 136.6	33	9.5	82	62	M10x21	81 106.4	13	21	8	11.5	8.6	3.3	G-M6	
MSA 45 A MSA 45 LA	60	120	137.7 169.5	37.5	10	100	80	M12x25	102.5 134.3	13	25	10	13.5	10.6	3.3	G-PT1/8	

Model No.	Rail dimension					Basic load rating		Static moment rating			Weight	
	Width W ₁	Height H ₁	Pitch P	E std.	D x h x d	Dynamic C kN	Static C ₀ kN	M _P kN-m	M _Y kN-m	M _R kN-m	Carriage kg	Rail kg/m
MSA 15 A	15	15	60	20	7.5 x 5.3 x 4.5	11.8	18.9	0.12	0.12	0.14	0.18	1.5
MSA 20 A MSA 20 LA	20	18	60	20	9.5 x 8.5 x 6	19.2 23.3	29.5 39.3	0.23 0.39	0.23 0.39	0.29 0.38	0.4 0.52	2.4
MSA 25 A MSA 25 LA	23	22	60	20	11 x 9 x 7	28.1 34.4	42.4 56.6	0.39 0.67	0.39 0.67	0.48 0.63	0.62 0.82	3.4
MSA 30 A MSA 30 LA	28	26	80	20	14 x 12 x 9	39.2 47.9	57.8 77.0	0.62 1.07	0.62 1.07	0.79 1.05	1.09 1.43	4.8
MSA 35 A MSA 35 LA	34	29	80	20	14 x 12 x 9	52.0 63.6	75.5 100.6	0.93 1.60	0.93 1.60	1.25 1.67	1.61 2.11	6.6
MSA 45 A MSA 45 LA	45	38	105	22.5	20 x 17 x 14	83.8 102.4	117.9 157.3	1.81 3.13	1.81 3.13	2.57 3.43	2.98 3.9	11.5

Note: Request for size 55 and 65 MSA-A / MSA-LA carriage, please refer to MSA-E / MSA-LE carriage type.

21.12 Dimensions of MSA-E / MSA-LE

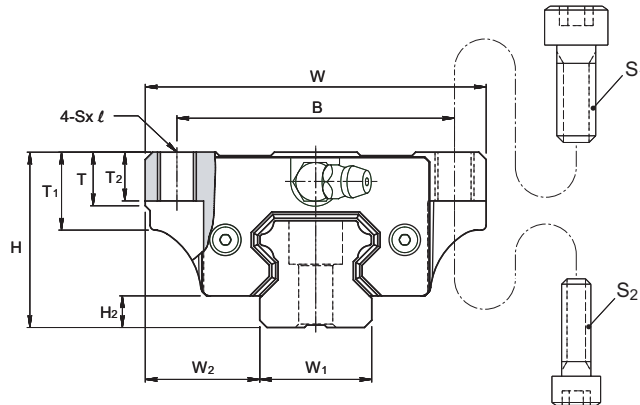

Model No.	Bolt Size	
	S ₁	S ₂
MSA 15	M5	M4
MSA 20	M6	M5
MSA 25	M8	M6
MSA 30	M10	M8
MSA 35	M10	M8
MSA 45	M12	M10
MSA 55	M14	M12
MSA 65	M16	M14

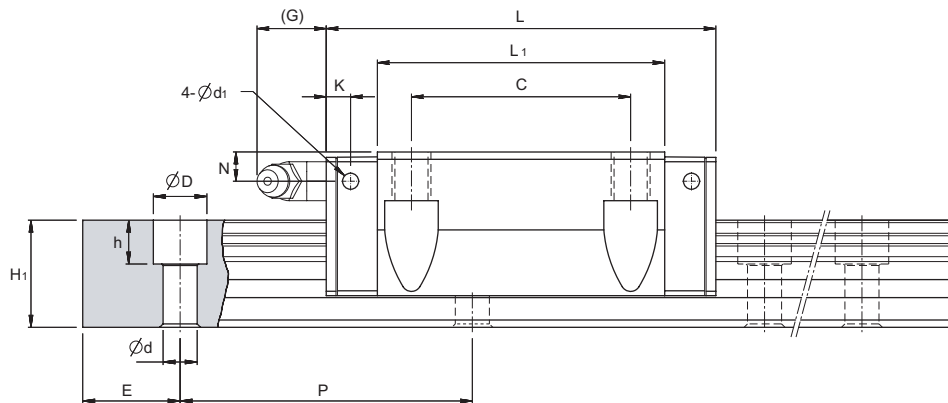
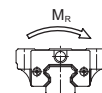
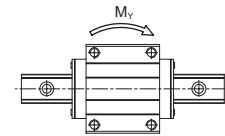
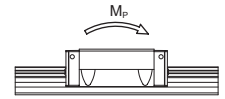

Unit : mm

Model No.	External Dimension					Carriage dimension											
	Height H	Width W	Length L	W ₂	H ₂	B	C	SxL	L ₁	T	T ₁	T ₂	N	G	K	d ₁	Grease Nipple
MSA 15 E	24	47	56.3	16	4.2	38	30	M5x7	39.3	7	11	7	4.3	7	3.2	3.3	G-M4
MSA 20 E	30	63	72.9	21.5	5	53	40	M6x10	51.3	7	10	10	5	12	5.8	3.3	G-M6
MSA 20 LE			88.8						67.2								
MSA 25 E	36	70	81.6	23.5	6.5	57	45	M8x10	59	11	16	10	6	12	5.8	3.3	G-M6
MSA 25 LE			100.6						78								
MSA 30 E	42	90	97	31	8	72	52	M10x10	71.4	11	18	10	7	12	6.5	3.3	G-M6
MSA 30 LE			119.2						93.6								
MSA 35 E	48	100	111.2	33	9.5	82	62	M10x13	81	13	21	13	8	11.5	8.6	3.3	G-M6
MSA 35 LE			136.6						106.4								
MSA 45 E	60	120	137.7	37.5	10	100	80	M12x15	102.5	13	25	15	10	13.5	10.6	3.3	G-PT1/8
MSA 45 LE			169.5						134.3								
MSA 55 E	70	140	161.5	43.5	13	116	95	M14x17	119.5	19	32	17	11	13.5	8.6	3.3	G-PT1/8
MSA 55 LE			199.5						157.5								
MSA 65 E	90	170	199	53.5	15	142	110	M16x23	149	21.5	37	23	19	13.5	8.6	3.3	G-PT1/8
MSA 65 LE			253						203								

Model No.	Rail dimension				Basic load rating		Static moment rating			Weight		
	Width W ₁	Height H ₁	Pitch P	E std.	D x h x d	Dynamic C kN	Static C ₀ kN	M _p kN-m	M _y kN-m	M _r kN-m	Carriage kg	Rail kg/m
MSA 15 E	15	15	60	20	7.5 x 5.3 x 4.5	11.8	18.9	0.12	0.12	0.14	0.18	1.5
MSA 20 E	20	18	60	20	9.5 x 8.5 x 6	19.2	29.5	0.23	0.23	0.29	0.4	2.4
MSA 20 LE						23.3	39.3	0.39	0.39	0.38	0.52	
MSA 25 E	23	22	60	20	11 x 9 x 7	28.1	42.4	0.39	0.39	0.48	0.62	3.4
MSA 25 LE						34.4	56.6	0.67	0.67	0.63	0.82	
MSA 30 E	28	26	80	20	14 x 12 x 9	39.2	57.8	0.62	0.62	0.79	1.09	4.8
MSA 30 LE						47.9	77.0	1.07	1.07	1.05	1.43	
MSA 35 E	34	29	80	20	14 x 12 x 9	52.0	75.5	0.93	0.93	1.25	1.61	6.6
MSA 35 LE						63.6	100.6	1.60	1.60	1.67	2.11	
MSA 45 E	45	38	105	22.5	20 x 17 x 14	83.8	117.9	1.81	1.81	2.57	2.98	11.5
MSA 45 LE						102.4	157.3	3.13	3.13	3.43	3.9	
MSA 55 E	53	44	120	30	23 x 20 x 16	123.6	169.8	3.13	3.13	4.50	4.17	15.5
MSA 55 LE						151.1	226.4	5.40	5.40	6.00	5.49	
MSA 65 E	63	53	150	35	26 x 22 x 18	198.8	265.3	6.11	6.11	8.36	8.73	21.9
MSA 65 LE						253.5	375.9	11.84	11.84	11.84	11.89	

21.13 Dimensions of MSA-S / MSA-LS

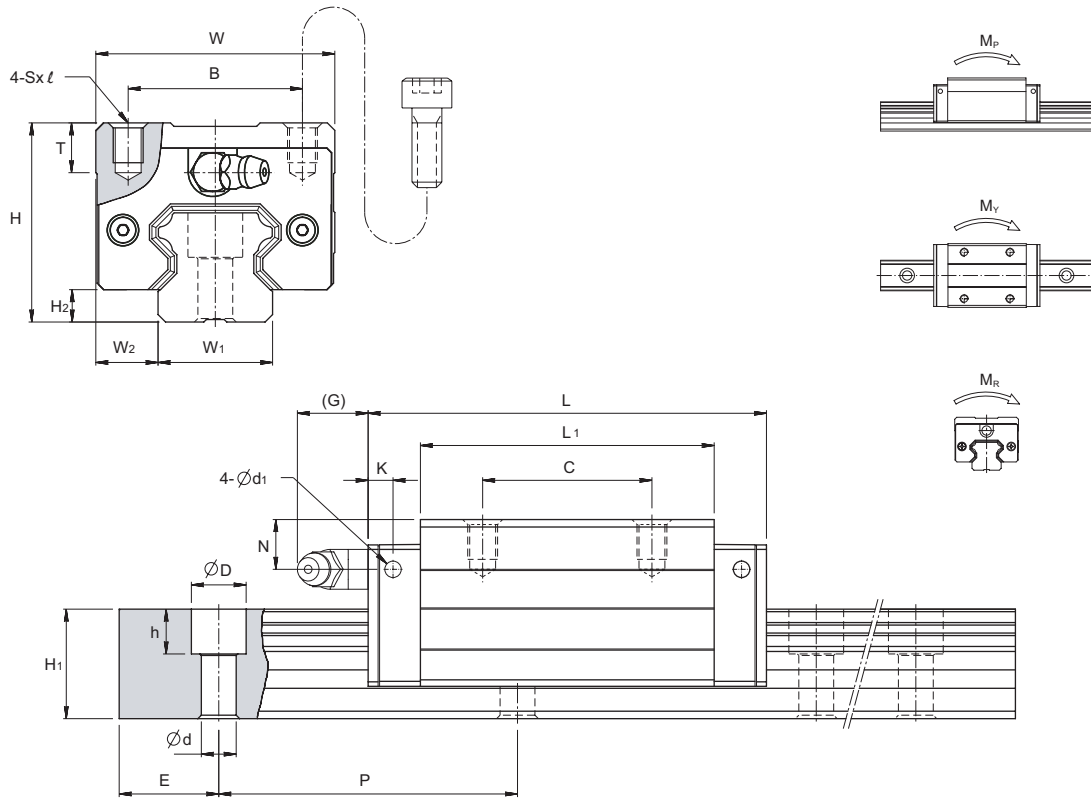

Unit : mm

Model No.	External dimension						Carriage dimension									
	Height H	Width W	Length L	W_2	H_2	B	C	$S \times L$	L_1	T	N	G	K	d_1	Grease Nipple	
MSA 15 S	28	34	56.3	9.5	4.2	26	26	M4x5	39.3	7.2	8.3	7	3.2	3.3	G-M4	
MSA 20 S MSA 20 LS	30	44	72.9 88.8	12	5	32	36 50	M5x6	51.3 67.2	8	5	12	5.8	3.3	G-M6	
MSA 25 S MSA 25 LS	40	48	81.6 100.6	12.5	6.5	35	35 50	M6x8	59 78	10	10	12	5.8	3.3	G-M6	
MSA 30 S MSA 30 LS	45	60	97 119.2	16	8	40	40 60	M8x10	71.4 93.6	11.7	10	12	6.5	3.3	G-M6	
MSA 35 S MSA 35 LS	55	70	111.2 136.6	18	9.5	50	50 72	M8x12	81 106.4	12.7	15	11.5	8.6	3.3	G-M6	
MSA 45 S MSA 45 LS	70	86	137.7 169.5	20.5	10	60	60 80	M10x17	102.5 134.3	16	20	13.5	10.6	3.3	G-PT1/8	
MSA 55 S MSA 55 LS	80	100	161.5 199.5	23.5	13	75	75 95	M12x18	119.5 157.5	18	21	13.5	8.6	3.3	G-PT1/8	
MSA 65 S MSA 65 LS	90	126	199 253	31.5	15	76	70 120	M16x20	149 203	23	19	13.5	8.6	3.3	G-PT1/8	

Model No.	Rail dimension					Basic load rating		Static moment rating			Weight	
	Width W_1	Height H_1	Pitch P	E std.	$D \times h \times d$	Dynamic C kN	Static C_0 kN	M_p kN-m	M_y kN-m	M_R kN-m	Carriage kg	Rail kg/m
MSA 15 S	15	15	60	20	7.5 x 5.3 x 4.5	11.8	18.9	0.12	0.12	0.14	0.18	1.5
MSA 20 S MSA 20 LS	20	18	60	20	9.5 x 8.5 x 6	19.2 23.3	29.5 39.3	0.23 0.39	0.23 0.39	0.29 0.38	0.3 0.39	2.4
MSA 25 S MSA 25 LS	23	22	60	20	11 x 9 x 7	28.1 34.4	42.4 56.6	0.39 0.67	0.39 0.67	0.48 0.63	0.52 0.68	3.4
MSA 30 S MSA 30 LS	28	26	80	20	14 x 12 x 9	39.2 47.9	57.8 77.0	0.62 1.07	0.62 1.07	0.79 1.05	0.86 1.12	4.8
MSA 35 S MSA 35 LS	34	29	80	20	14 x 12 x 9	52.0 63.6	75.5 100.6	0.93 1.60	0.93 1.60	1.25 1.67	1.45 1.9	6.6
MSA 45 S MSA 45 LS	45	38	105	22.5	20 x 17 x 14	83.8 102.4	117.9 157.3	1.81 3.13	1.81 3.13	2.57 3.43	2.83 3.7	11.5
MSA 55 S MSA 55 LS	53	44	120	30	23 x 20 x 16	123.6 151.1	169.8 226.4	3.13 5.40	3.13 5.40	4.50 6.00	4.12 4.91	15.5
MSA 65 S MSA 65 LS	63	53	150	35	26 x 22 x 18	198.8 253.5	265.3 375.9	6.11 11.84	6.11 11.84	8.36 11.84	6.43 8.76	21.9

22. MSB Series - Compact Type

22.1 Carriage Type

Medium Load

MSB-TE Type

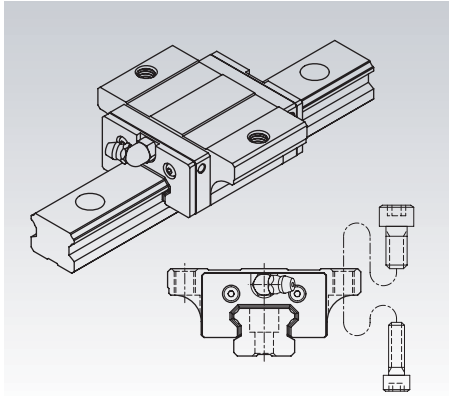

This type offers the installation either from top or bottom side of carriage.

MSB-TS Type

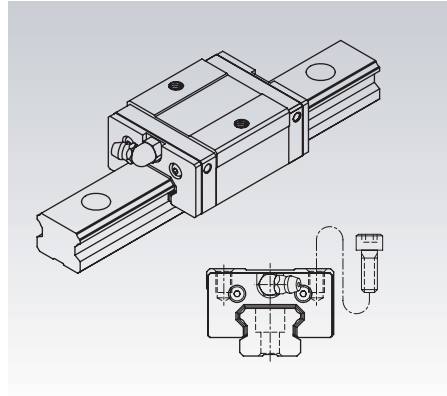

Square type with smaller width and can be installed from top side of carriage.

Heavy Load

MSB-E Type

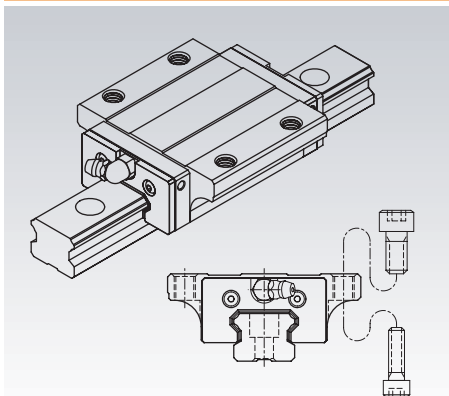

All dimensions are same as MSB-TE except the length is longer, which makes it more rigid.

MSB-S Type

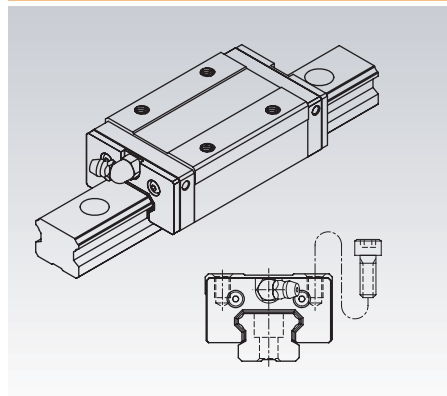

All dimensions are same as MSB-TS except the length is longer, which makes it more rigid.

22.2 Rail Type

Counter-bore (R, U type)

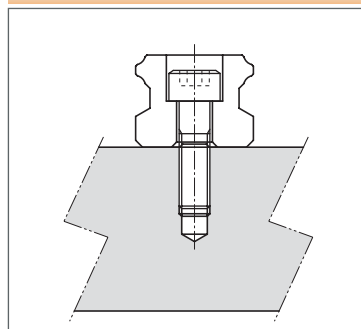

Tapped Hole (T type)

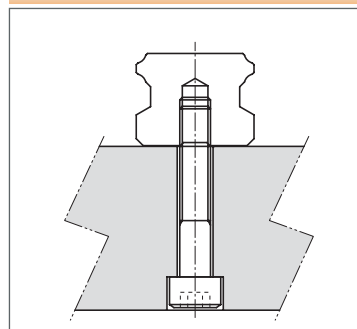

22.3 Description of Specification

(1) Non-Interchangeable Type

	MSB	25	E	2	SS	F0	A	+ R	1200	- 20	/ 40	P	A	II
Series :	MSB													
Size :	15, 20, 25, 30, 35													
Carriage type :	(1) Medium load TE : Flange type, mounting either from top or bottom TS : Square type (2) Heavy load E : Flange type, mounting either from top or bottom S : Square type (3) Ultra heavy load LS : Square type													
Number of carriages per rail :	1, 2, 3 ...													
Dust protection option :	No symbol, UU, SS, ZZ, DD, KK, LL, RR													
Preload :	FC (Light preload) , F0 (Medium preload) , F1 (Heavy preload)													
Code of special carriage :	No symbol, A, B ...													
Rail type :	R, U⁽¹⁾ (Counter-bore type) , T (Tapped hole type)													
Rail length (mm)														
Rail hole pitch from start side (E1 , see Fig.16)														
Rail hole pitch to the end side (E2 , see Fig.16)														
Accuracy grade :	N, H, P, SP, UP													
Code of special rail :	No symbol, A, B ...													
Number of rails per axis :	No symbol , II, III, IV ...													

Note⁽¹⁾: **U** type rail is only applicable for MSB15 with M4 mounting hole.

Fig.16

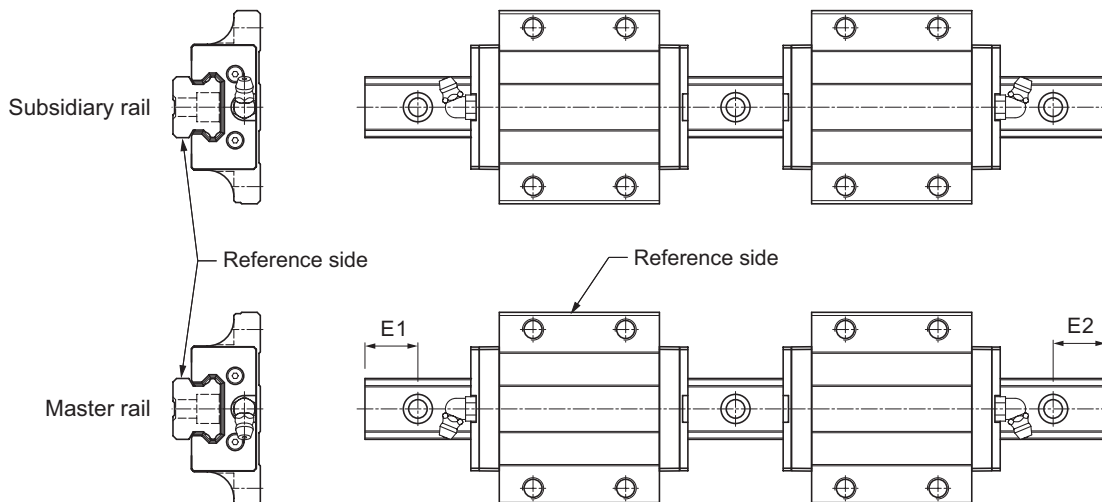

(2) Interchangeable Type

Code of Carriage

	MSB	25	E	SS	FC	N	A
Series : MSB							
Size : 15, 20, 25, 30, 35							
Carriage type : (1) Medium load TE : Flange type, mounting either from top or bottom TS : Square type (2) Heavy load E : Flange type, mounting either from top or bottom S : Square type (3) Ultra heavy load LS : Square type							
Dust protection option : No symbol, UU, SS, ZZ, DD, KK, LL, RR							
Preload : FC (Light preload)							
Accuracy grade : N, H							
Code of special carriage : No symbol, A, B ...							

Code of Rail

	MSB	25	R	1200	-20	/ 40	N	A
Series : MSB								
Size : 15, 20, 25, 30, 35								
Rail Type : R, U⁽¹⁾ (Counter-bore type), T (Tapped hole type)								
Rail length (mm)								
Rail hole pitch from start side (E1 , see Fig.16)								
Rail hole pitch to the end side (E2 , see Fig.16)								
Accuracy grade : N, H								
Code of special rail : No symbol, A, B ...								

Note⁽¹⁾: **U** type rail is only applicable for MSB15 with M4 mounting hole.

22.4 Accuracy Grade

The accuracy of MSB series is divided into 5 classes, normal grade (N), high precision (H), precision (P), super precision (SP), and ultra precision (UP), as shown in Table 19.

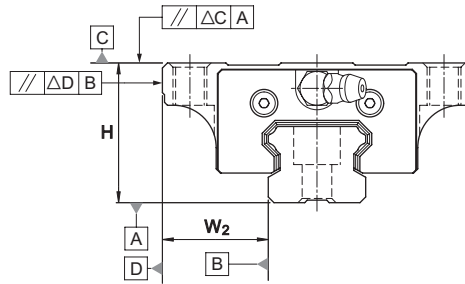
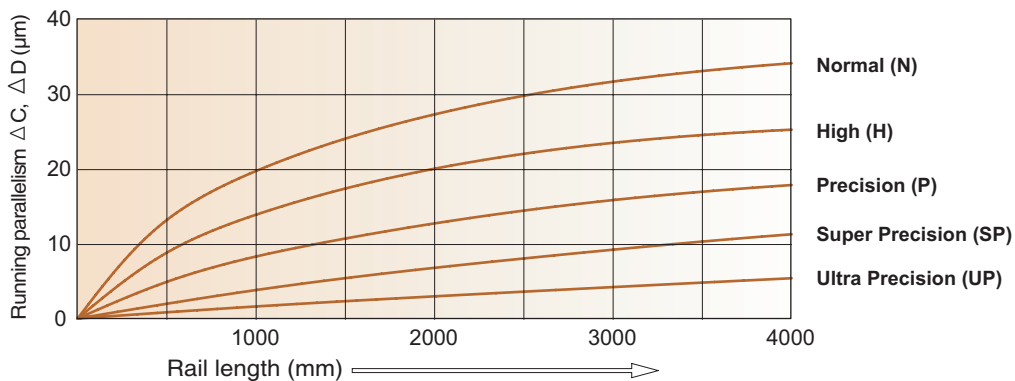

Table 19 Accuracy Grade

Unit: mm

Model No.	Item	Accuracy Grade				
		Normal N	High H	Precision P	Super Precision SP	Ultra Precision UP
MSB 15 MSB 20	Tolerance for height H	±0.1	±0.03	0 -0.03	0 -0.015	0 -0.008
	Height difference ΔH	0.02	0.01	0.006	0.004	0.003
	Tolerance for distance W ₂	±0.1	±0.03	0 -0.03	0 -0.015	0 -0.008
	Difference in distance W ₂ (ΔW ₂)	0.02	0.01	0.006	0.004	0.003
	Running parallelism of surface C with surface A	ΔC (see Fig.17)				
	Running parallelism of surface D with surface B	ΔD (see Fig.17)				
MSB 25 MSB 30 MSB 35	Tolerance for height H	±0.1	±0.04	0 -0.04	0 -0.02	0 -0.01
	Height difference ΔH	0.02	0.015	0.007	0.005	0.003
	Tolerance for distance W ₂	±0.1	±0.04	0 -0.04	0 -0.02	0 -0.01
	Difference in distance W ₂ (ΔW ₂)	0.03	0.015	0.007	0.005	0.003
	Running parallelism of surface C with surface A	ΔC (see Fig.17)				
	Running parallelism of surface D with surface B	ΔD (see Fig.17)				

Fig.17 Running Parallelism of Carriage



22.5 Preload Grade and Rigidity

(1) Preload grade

The preload of MSB series is represented by radial clearance which is divided into three grades, light (FC), medium (F0), heavy (F1), as shown in Table 20.

Table 20 Preload grade and radial clearance

Unit : m

Preload Model No.	Light	Medium	Heavy
	FC	F0	F1
MSB 15	-4 ~ +2	-10 ~ -4	-
MSB 20	-5 ~ +2	-12 ~ -5	-17 ~ -12
MSB 25	-6 ~ +3	-15 ~ -6	-21 ~ -15
MSB 30	-7 ~ +4	-18 ~ -7	-26 ~ -18
MSB 35	-8 ~ +4	-20 ~ -8	-31 ~ -20

(2) Rigidity value

The rigidity values of preloaded linear guideway of MSB series are shown as Table 21.

Table 21 Rigidity value

	Model No.	Rigidity Value (N/ m)		
		Light preload FC	Medium preload F0	Heavy preload F1
Medium Load Type	MSB15 TE, TS	127	188	-
	MSB20 TE, TS	150	247	292
	MSB25 TE, TS	192	337	394
	MSB30 TE, TS	215	380	444
Heavy Load Type	MSB15 E, S	202	336	-
	MSB20 E, S	228	395	462
	MSB25 E, S	282	497	581
	MSB30 E, S	342	601	702
	MSB35 S	396	699	817
Ultra Heavy Load Type	MSB35 LS	513	894	1047

22.6 Dust Proof

(1) Contamination protection

MSB series of linear guideway offers various kinds of dust protection accessory to keep the foreign matters from entering into the carriage.

End seal

Two types sealing are available:

1. Bidirectional seal for high dust protection required.
2. Monodirectional seal for low frictional resistance required.

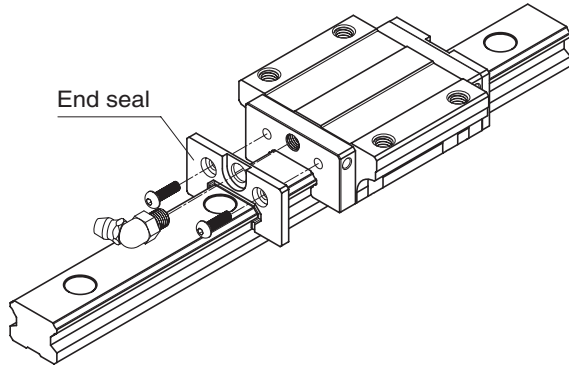

Bottom seal

Preventing the inclusion of foreign matters from bottom of carriage.

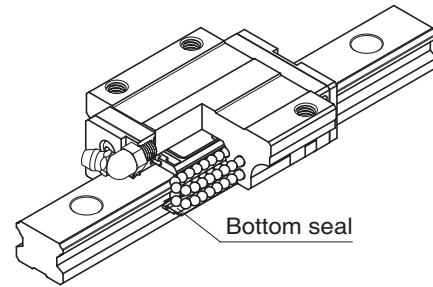

Double end seal

For enhancing the dust protection.

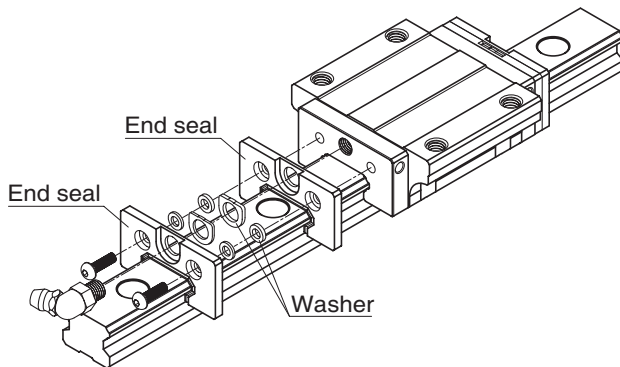

Metallic scraper

Removing spatters, iron chips, and large foreign matters as well as protecting the end seals.

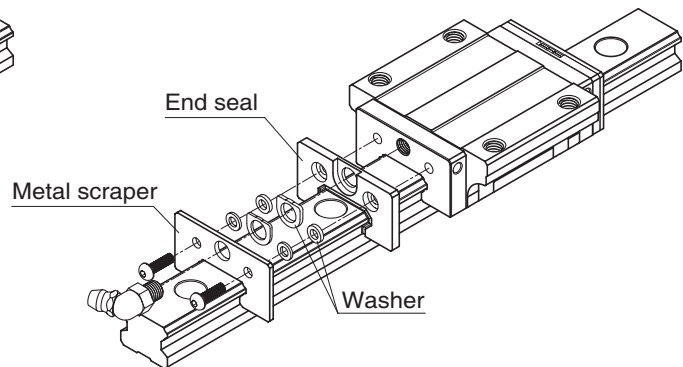

(2) Code of contamination protection

The codes for selection of dust protection accessory are shown as Table 22.

The increment to be added to the length of carriage with different applications of dust protection accessory is shown as Table 23.

Table 22 Code of contamination protection

Code	Contamination Protection
No symbol	Scraper (both ends)
UU	Bidirectional end seal (both ends)
SS	Bidirectional end seal + Bottom seal
ZZ	SS + Scraper
DD	Double bidirectional end seal + Bottom seal
KK	DD + Scraper
LL	Low frictional end seal
RR	LL + Bottom seal

Table 23 Types of seal to the increment to the carriage overall length

Unit : mm

Model No.	No symbol	UU	SS	LL	RR	ZZ	DD	KK
MSB 15	-	-	-	-	-	5	5	10
MSB 20	1	-	-	-	-	7	6	13
MSB 25	1	-	-	-	-	7	6	13
MSB 30	1	-	-	-	-	7	6	13
MSB 35	0.6	-	-	-	-	7.8	7.2	15

(3) Resistance value of seal

The maximum resistance value of seals type UU when it is applied with grease is shown as Table 24.

Table 24 Seal resistance value

Unit : N

Model No.	Resistance
MSB 15	2
MSB 20	3
MSB 25	4
MSB 30	5.5
MSB 35	9

22.7 The Shoulder Height and Corner Radius for Installation

The mounting surface of rails and carriages are machined precisely for aiding in positioning and assemble with high accuracy. The shoulder height and corner radius providing enough mounting space for not to interfere with chamfers made on rails and carriages.

The dimensions of shoulder height and corner radius are shown as Table 25.

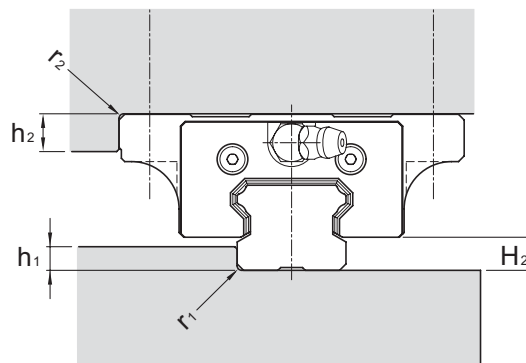

Table 25 Shoulder height and corner radius of mounting surface

Unit : mm

Model No.	r ₁ (max.)	r ₂ (max.)	h ₁	h ₂	H ₂
MSB 15	0.5	0.5	3	4	4.5
MSB 20	0.5	0.5	4	5	6
MSB 25	1	1	5	5	7
MSB 30	1	1	7	5	9.5
MSB 35	1	1	8	6	9.5

22.8 Dimensional Tolerance of Mounting Surface

Thanks to the self alignment capability of MSB series, the minor dimensional error in mounting surface could be compensated and achieves smooth linear motion. The tolerances of parallelism between two axes are shown as below.

The parallel deviation between two axes (e_1)

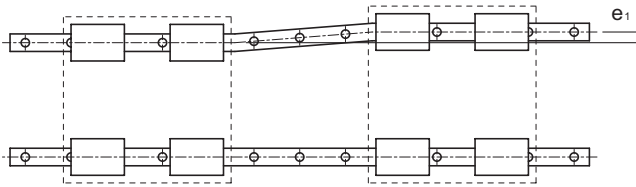

Table 26 Parallel deviation (e_1)

Unit : m

Model No.	Preload Grade		
	FC	F0	F1
MSB 15	25	18	-
MSB 20	25	20	18
MSB 25	30	22	20
MSB 30	40	30	27
MSB 35	50	35	30

Level difference between two axes (e_2)

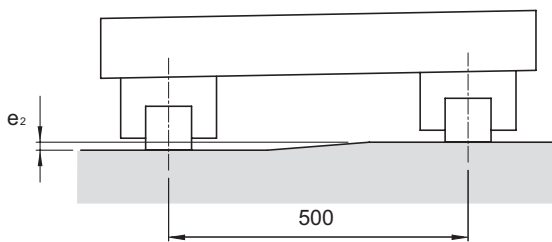

Table 27 Level difference between two axes (e_2)

Unit : m

Model No.	Preload Grade		
	FC	F0	F1
MSB 15	130	85	-
MSB 20	130	85	50
MSB 25	130	85	70
MSB 30	170	110	90
MSB 35	210	150	120

Note: The permissible values in table are applicable when the span is 500mm wide.

22.9 Tapped-hole Rail Dimensions

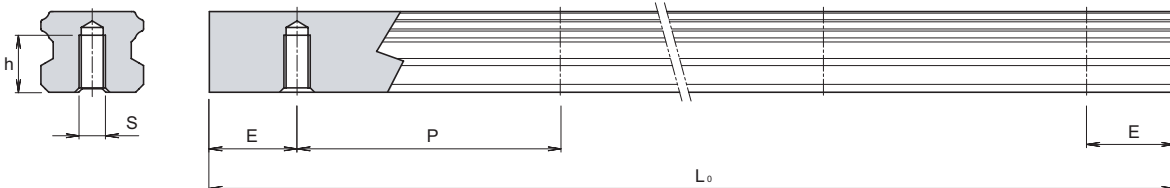

Rail Model	S	h(mm)
MSB 15 T	M5	7
MSB 20 T	M6	9
MSB 25 T	M6	10
MSB 30 T	M8	14
MSB 35 T	M8	16

22.10 Rail Standard and Maximum Length

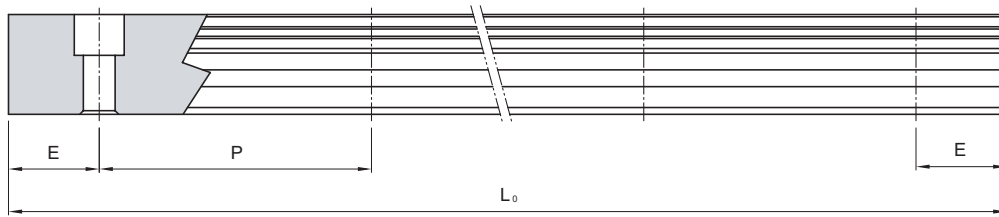

Unit : mm

Model No.	MSB 15	MSB 20	MSB 25	MSB 30	MSB 35
Rail Standard Length (L ₀)	160	220	220	280	280
	220	280	280	360	360
	280	340	340	440	440
	340	400	400	520	520
	400	460	460	600	600
	460	520	520	680	680
	520	580	580	760	760
	580	640	640	840	840
	640	700	700	920	920
	700	760	760	1000	1000
	760	820	820	1080	1080
	820	880	880	1160	1160
	880	940	940	1240	1240
	940	1000	1000	1320	1320
	1000	1060	1060	1400	1400
	1060	1120	1120	1480	1480
	1120	1180	1180	1560	1560
	1180	1240	1240	1640	1640
	1240	1300	1300	1720	1720
	1300	1360	1360	1800	1800
	1360	1420	1420	1880	1880
	1420	1480	1480	1960	1960
	1480	1540	1540	2040	2040
	1540	1600	1600	2120	2120
	1600	1660	1660	2200	2200
	1660	1720	1720	2280	2280
	1720	1780	1780	2360	2360
	1780	1840	1840	2440	2440
	1960	1900	1900	2520	2520
		1960	1960	2600	2600
		2020	2020	2680	2680
		2080	2080	2760	2760
		2140	2140	2840	2840
		2200	2200	2920	2920
		2260	2260	3000	3000
		2320	2320	3080	3080
		2380	2380	3160	3160
		2440	2440	3240	3240
		2500	2500	3320	3320
		2560	2560	3400	3400
	2620	2620	3480	3480	
	2680	2680	3560	3560	
	2740	2740	3640	3640	
	2980	2800	3960	3960	
		2860			
		2920			
		2980			
		3040			
		3100			
		3160			
		3220			
		3280			
		3340			
		3400			
		3460			
		3520			
		3580			
		3640			
		3700			
		3760			
		4000			
Standard Pitch (P)	60	60	60	80	80
Standard E	20	20	20	20	20
Minimum E	5	6	7	7	8
Max. Length L ₀	2000	3000	4000	4000	4000

22.11 Dimensions of MSB-TE / MSB-E

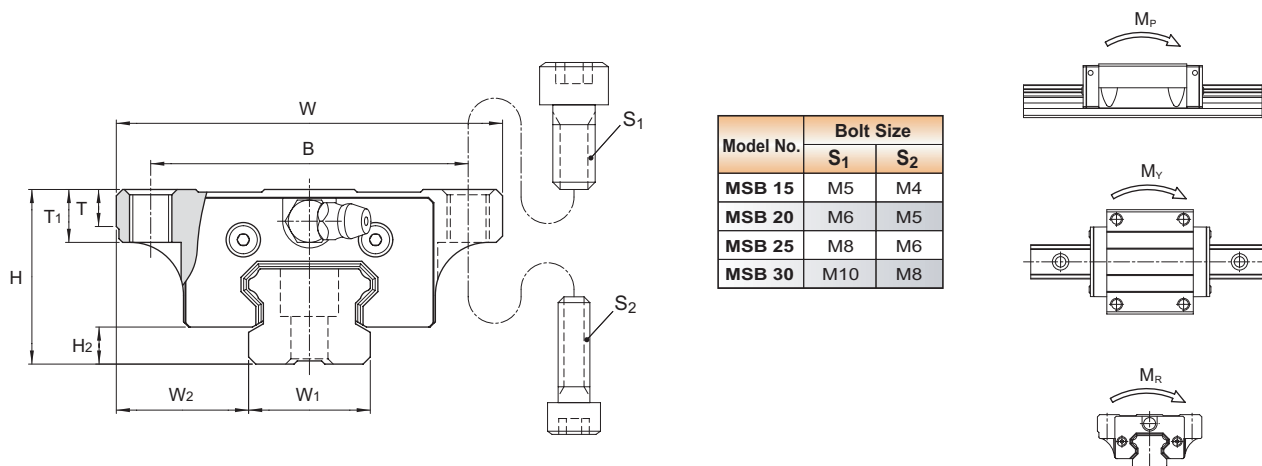

Model No.	Bolt Size	
	S ₁	S ₂
MSB 15	M5	M4
MSB 20	M6	M5
MSB 25	M8	M6
MSB 30	M10	M8

MSB-E

MSB-TE

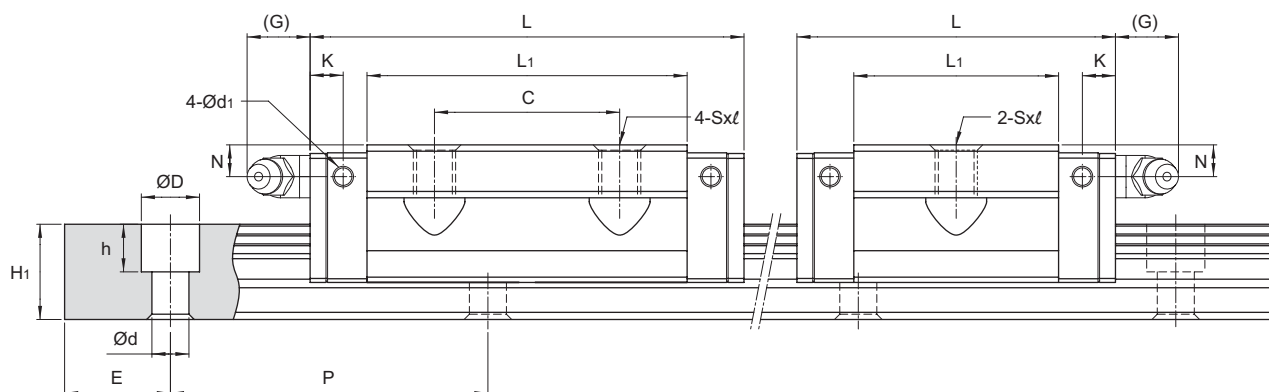

Unit : mm

Model No.	External Dimension					Carriage dimension											Grease Nipple
	Height H	Width W	Length L	W ₂	H ₂	B	C	SxL	L ₁	T	T ₁	N	G	K	d ₁		
MSB 15 TE	24	52	40	18.5	4.5	41	-	M5x7	23.5	5	7	5.5	5.5	5.1	3.3	G-M4	
MSB 15 E			57				26		40.5								
MSB 20 TE	28	59	48	19.5	6	49	-	M6x9	29	5	9	5.5	12	5.9	3.3	G-M6	
MSB 20 E			67				32		48								
MSB 25 TE	33	73	60.2	25	7	60	-	M8x10	38.7	7	10	6	12	6.3	3.3	G-M6	
MSB 25 E			82				35		60.5								
MSB 30 TE	42	90	68	31	9.5	72	-	M10x10	43.3	7	10	8	12	6.3	3.3	G-M6	
MSB 30 E			96.7				40		72								

Model No.	Rail dimension				Basic load rating		Static moment rating			Weight		
	Width W ₁	Height H ₁	Pitch P	E std.	D x h x d	Dynamic C kN	Static C ₀ kN	M _P kN-m	M _Y kN-m	M _R kN-m	Carriage kg	Rail kg/m
MSB 15 TE	15	12.5	60	20	※ 6 x 4.5 x 3.5	6.7	9.6	0.04	0.04	0.07	0.12	1.2
MSB 15 E					(7.5 x 5.3 x 4.5)	10.0	16.9	0.10	0.10	0.13	0.21	
MSB 20 TE	20	15	60	20	9.5 x 8.5 x 6	9.7	14.2	0.07	0.07	0.14	0.20	2
MSB 20 E						13.9	23.6	0.18	0.18	0.24	0.34	
MSB 25 TE	23	18	60	20	11 x 9 x 7	15.6	22.1	0.13	0.13	0.26	0.39	3
MSB 25 E						22.3	36.9	0.35	0.35	0.43	0.60	
MSB 30 TE	28	23	80	20	11 x 9 x 7	23.1	31.8	0.23	0.23	0.45	0.65	4.4
MSB 30 E						32.9	53.1	0.60	0.60	0.74	1.08	

※ Rail mounting holes for M3 (6x4.5x3.5) and M4 (7.5x5.3x4.5) are available for MSB15 rail. The codes of rail type are **MSB15R** for M3 mounting holes, and **MSB15U** for M4 mounting holes.

22.12 Dimensions of MSB-TS / MSB-S / MSB-LS

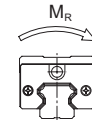
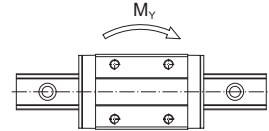
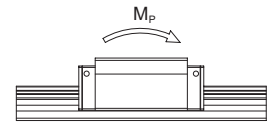
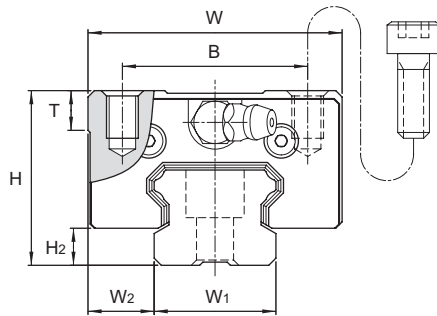

MSB-S / MSB-LS

MSB-TS

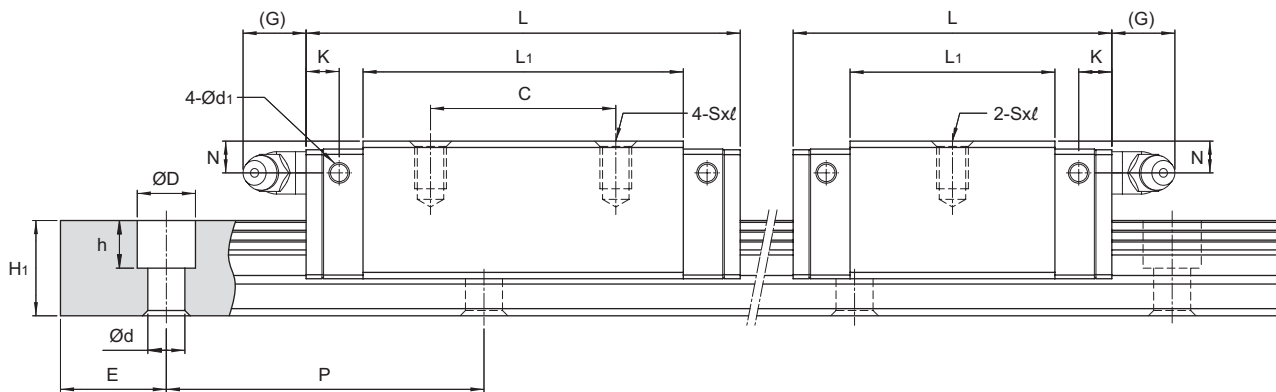

Unit : mm

Model No.	External dimension					Carriage dimension										Grease Nipple
	Height H	Width W	Length L	W ₂	H ₂	B	C	SxL	L ₁	T	N	G	K	d ₁		
MSB 15 TS MSB 15 S	24	34	40 57	9.5	4.5	26	- 26	M4x6	23.5 40.5	6	5.5	5.5	5.1	3.3	G-M4	
MSB 20 TS MSB 20 S	28	42	48 67	11	6	32	- 32	M5x7	29 48	6	5.5	12	5.9	3.3	G-M6	
MSB 25 TS MSB 25 S	33	48	60.2 82	12.5	7	35	- 35	M6x9	38.7 60.5	8	6	12	6.3	3.3	G-M6	
MSB 30 TS MSB 30 S	42	60	68 96.7	16	9.5	40	- 40	M8x12	43.3 72	8	8	12	6.3	3.3	G-M6	
MSB 35 S MSB 35 LS	48	70	112 137.5	18	9.5	50	50 72	M8x12	80 105.5	12.5	8.5	11.5	9.8	3.3	G-M6	

Model No.	Rail dimension					Basic load rating		Static moment rating			Weight	
	Width W ₁	Height H ₁	Pitch P	E std.	D x h x d	Dynamic C kN	Static C ₀ kN	M _p kN-m	M _y kN-m	M _r kN-m	Carriage kg	Rail kg/m
MSB 15 TS MSB 15 S	15	12.5	60	20	* 6 x 4.5 x 3.5 (7.5 x 5.3 x 4.5)	6.7 10.0	9.6 16.9	0.04 0.10	0.04 0.10	0.07 0.13	0.09 0.16	1.2
MSB 20 TS MSB 20 S	20	15	60	20	9.5 x 8.5 x 6	9.7 13.9	14.2 23.6	0.07 0.18	0.07 0.18	0.14 0.24	0.16 0.26	2
MSB 25 TS MSB 25 S	23	18	60	20	11 x 9 x 7	15.6 22.3	22.1 36.9	0.13 0.35	0.13 0.35	0.26 0.43	0.29 0.45	3
MSB 30 TS MSB 30 S	28	23	80	20	11 x 9 x 7	23.1 32.9	31.8 53.1	0.23 0.60	0.23 0.60	0.45 0.74	0.52 0.86	4.4
MSB 35 S MSB 35 LS	34	27.5	80	20	14 x 12 x 9	52.0 63.6	75.5 100.6	0.93 1.60	0.93 1.60	1.28 1.71	1.13 1.49	6.2

* Rail mounting holes for M3 (6x4.5x3.5) and M4 (7.5x5.3x4.5) are available for MSB15 rail. The codes of rail type are **MSB15R** for M3 mounting holes, and **MSB15U** for M4 mounting holes.

23. **AMT** Linear Guideway with SL Lubricator

23.1 Construction and Features

Construction

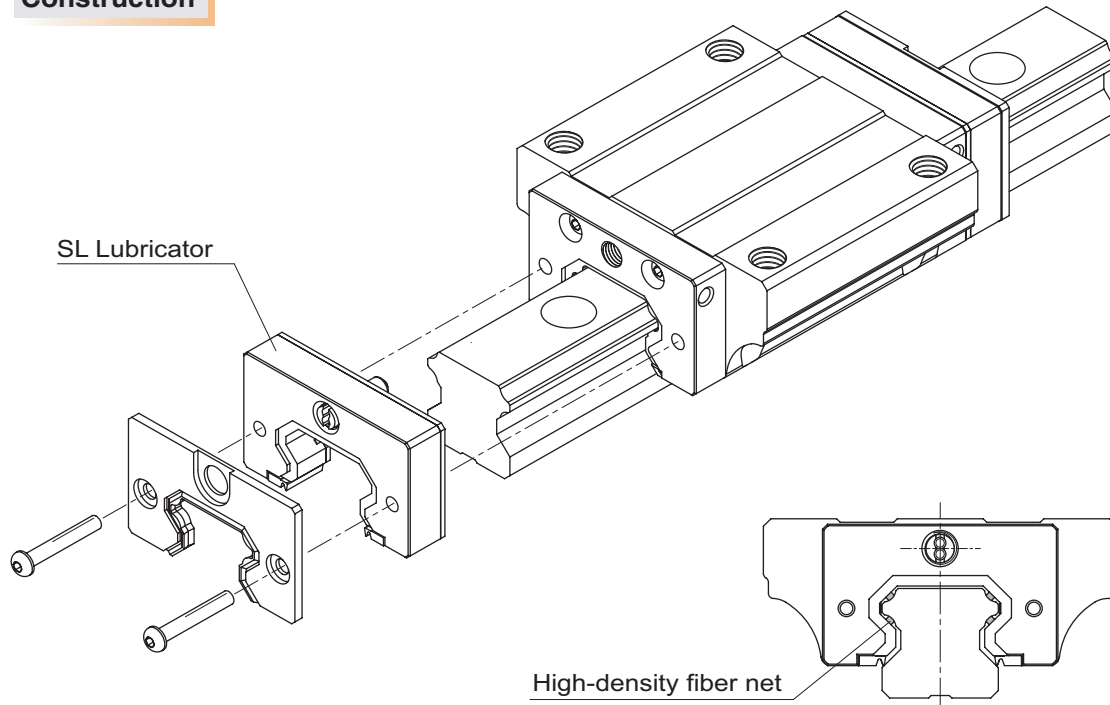

Features

AMT SL lubricator unit is designed with an oil reservoir which equipped with a high-density fiber net. Through the fiber net the lubricant can be steadily fed onto the surface of raceway to satisfy the required lubricating function.

1. Lengthening the interval between maintenance works

Contrary to the oil losing problem caused from ordinary lubrication, the SL lubricator effectively and evenly distribute needed amount of oil on to ball raceway during the movement. Therefore, the interval between maintenance works can be greatly extended.

2. To avert the pollution

Through the use of SL lubricator, only the needed amount of oil will be fed for the purpose of lubrication, thereby the oil is almost nothing to lose in application. As a result, the environment will not be contaminated by waste oil.

3. Cost reduction

Saving the expense from oil loss and lubricating device.

4. Enables the most suitable oil for the purpose of use to be selected

The SL lubricator makes it possible to select the most proper lubricant for your application of linear guideway.

23.2 Performance

1. Lengthening the interval between maintenance works

By using the SL lubricator, the interval between maintenance work can be lengthened at all load rating.

Running Test without Replenishment of Lubricant

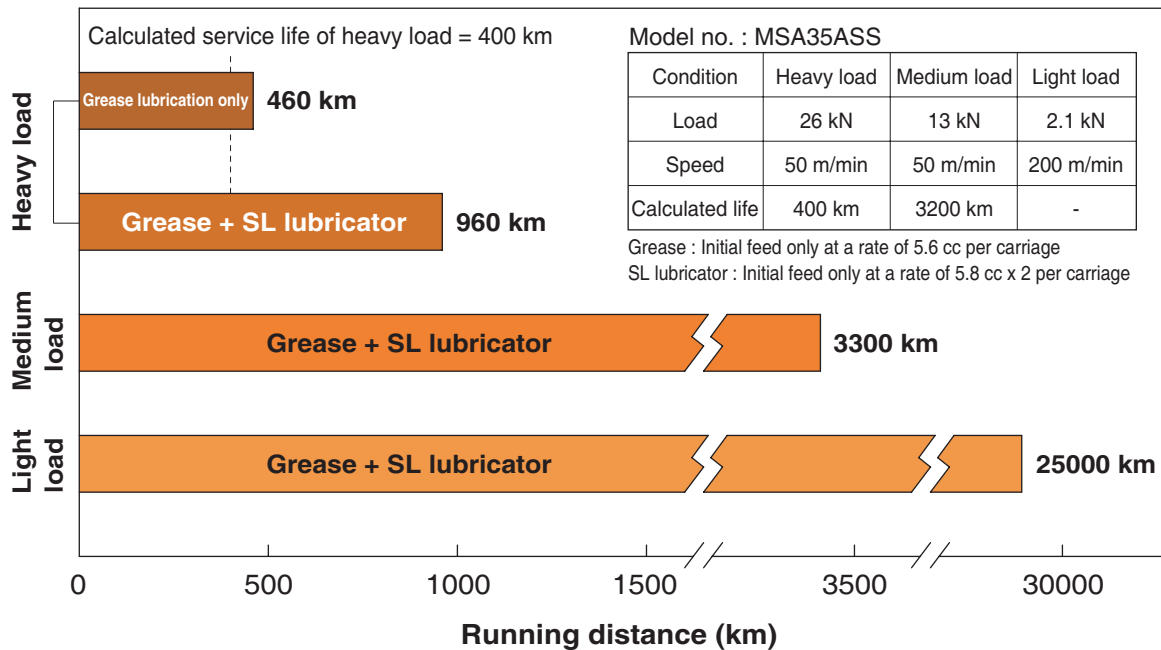

2. Effective use of lubricant

Since only the needed amount of lubricant will be applied to needed location, thereby effective use of lubricant can be achieved and the waste of lubricant can also be avoided.

Annual Lubricant Consumption per Carriage

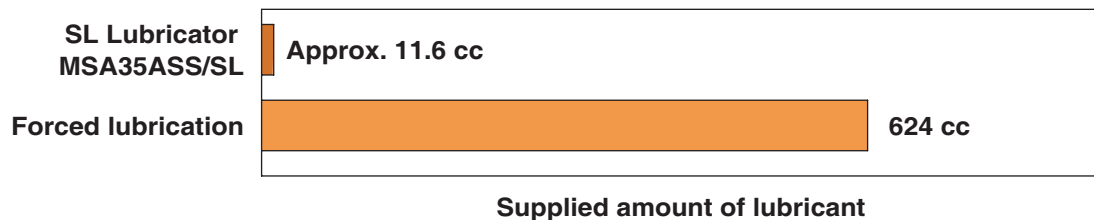

Amount of oil contained in SL Lubricator
 $5.8 \text{ cc} \times 2 / \text{carriage}$
 $= 11.6 \text{ cc}$



Forced lubrication
 $0.3 \text{ cc/hr} \times 8 \text{ hrs/day} \times 260 \text{ days/year}$
 $= 624 \text{ cc}$

23.3 Description of Specification

Non-Interchangeable Type

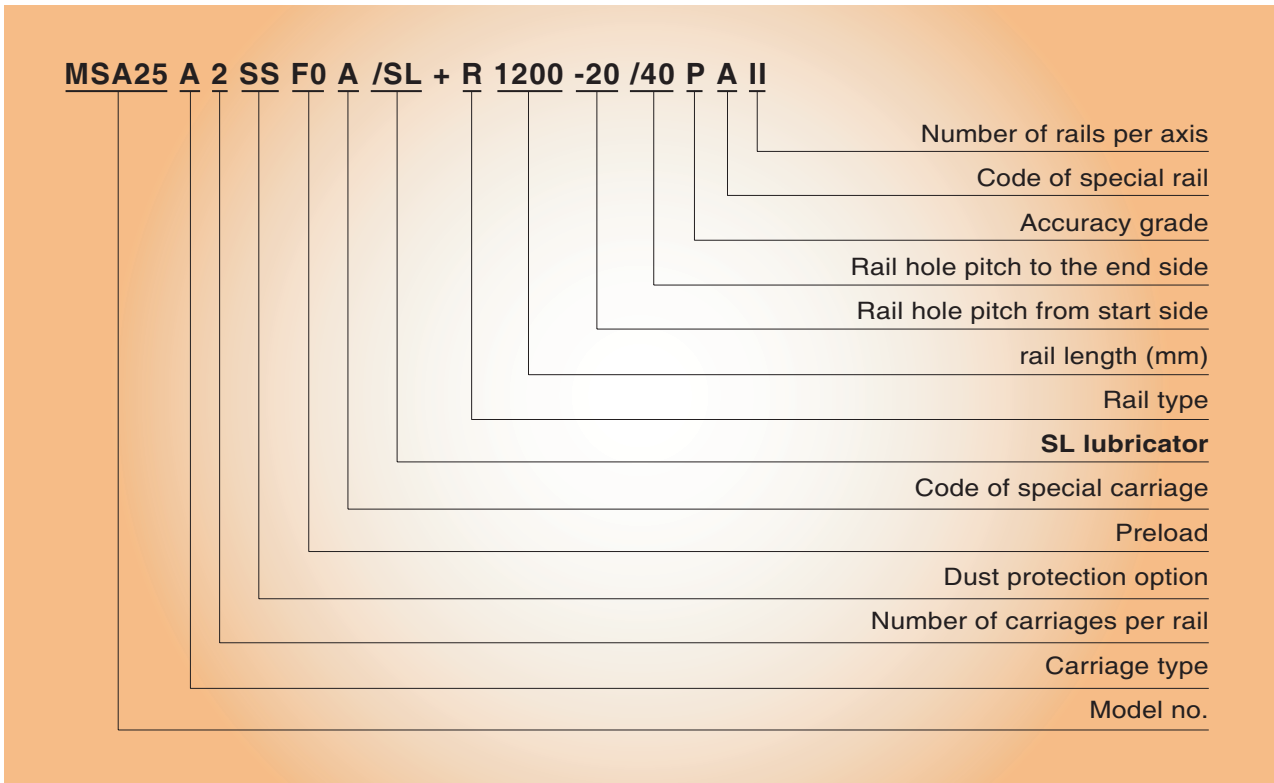

Interchangeable Type Carriage



23.4 Dimensions of the SL Lubricator

MSA Series

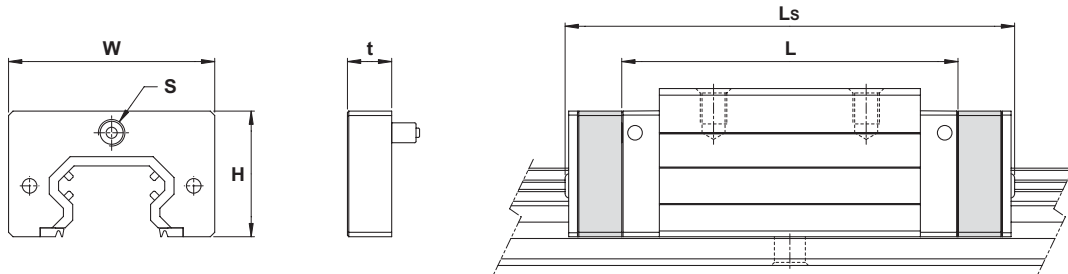

Model No.		SL Lubricator dimensions (mm)				Carriage dimensions (mm)	
		Height H	Width W	Thickness t	Tapped hole S	Standard length L	SL Lubricator overall length Ls
MSA15SL	A / E / S	19	31.2	10	M4	56.3	81.3
MSA20SL	A / E / S	21.2	42.8	10	M6	72.9	92.9
	LA / LE / LS					88.8	108.8
MSA25SL	A / E / S	28.5	46.8	10	M6	81.6	101.6
	LA / LE / LS					100.6	120.6
MSA30SL	A / E / S	32	57	10	M6	97	117
	LA / LE / LS					119.2	139.2
MSA35SL	A / E / S	36.5	68	10	M6	111.2	131.2
	LA / LE / LS					136.6	156.6
MSA45SL	A / E / S	49	83.6	15	1/8PT	137.7	167.7
	LA / LE / LS					169.5	199.5

MSB Series

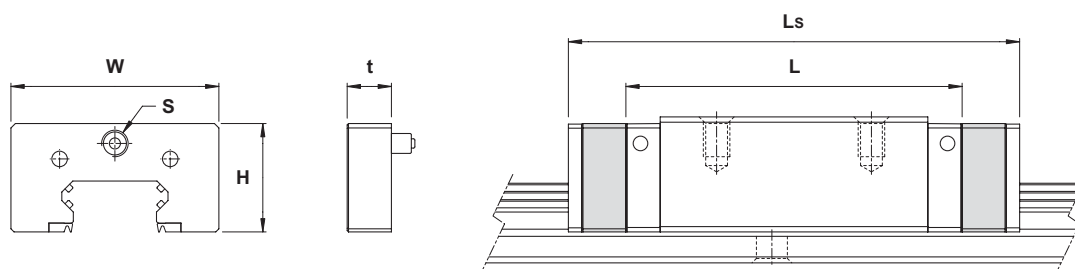

Model No.		SL Lubricator dimensions (mm)				Carriage dimensions (mm)	
		Height H	Width W	Thickness t	Tapped hole S	Standard length L	SL Lubricator overall length Ls
MSB15SL	TE / TS	18.5	33	10	M4	40	65
	E / S					57	82
MSB20SL	TE / TS	21.2	40.8	10	M6	48	68
	E / S					67	87
MSB25SL	TE / TS	24.5	47	10	M6	60.2	80.2
	E / S					82	102
MSB30SL	TE / TS	30.8	57	10	M6	68	88
	E / S					96.7	116.7

AMT Linear Guideway Request Form

Date :

Customer Name :			Address :			
Tel :						
Fax :			Machine Type :			
Contact Person :			Drawing No. :			
Installation Direction						
	<input type="checkbox"/> H type	<input type="checkbox"/> R type	<input type="checkbox"/> V type	<input type="checkbox"/> K type	<input type="checkbox"/> T type	<input type="checkbox"/> Others
Carriage Type	MSA- <input type="checkbox"/> A <input type="checkbox"/> LA <input type="checkbox"/> E <input type="checkbox"/> LE <input type="checkbox"/> S <input type="checkbox"/> LS			MSB- <input type="checkbox"/> TE <input type="checkbox"/> E <input type="checkbox"/> TS <input type="checkbox"/> S <input type="checkbox"/> LS		
Size	<input type="checkbox"/> 15 <input type="checkbox"/> 20 <input type="checkbox"/> 25 <input type="checkbox"/> 30 <input type="checkbox"/> 35 <input type="checkbox"/> 45 <input type="checkbox"/> 55 <input type="checkbox"/> 65					
No. of Carriages	<input type="checkbox"/> 1 <input type="checkbox"/> 2 <input type="checkbox"/> 3 <input type="checkbox"/> 4 <input type="checkbox"/> Others :					
Dust Protection	<input type="checkbox"/> No symbol <input type="checkbox"/> UU <input type="checkbox"/> SS <input type="checkbox"/> ZZ <input type="checkbox"/> DD <input type="checkbox"/> KK <input type="checkbox"/> LL <input type="checkbox"/> RR					
Preload Grade	<input type="checkbox"/> FC <input type="checkbox"/> F0 <input type="checkbox"/> F1					
Rail Type	<input type="checkbox"/> Counter-bore (R type) <input type="checkbox"/> Counter-bore (U type) <input type="checkbox"/> Tapped hole (T type)					
Rail Length & Pitch	Length :		E1 :	E2 :	E3 :	E4 :
Accuracy Grade	<input type="checkbox"/> N <input type="checkbox"/> H <input type="checkbox"/> P <input type="checkbox"/> SP <input type="checkbox"/> UP					
Rail per Axis	<input type="checkbox"/> 1 <input type="checkbox"/> 2 <input type="checkbox"/> 3 <input type="checkbox"/> Others :					
Lubrication Type	<input type="checkbox"/> Grease <input type="checkbox"/> Oil					
Lubrication Fitting	<input type="checkbox"/> Grease nipple (Code :) <input type="checkbox"/> Oil piping joint (Code :)					
Full Code of Specification						
Required Quantity						

Reference surface & Lubrication Location

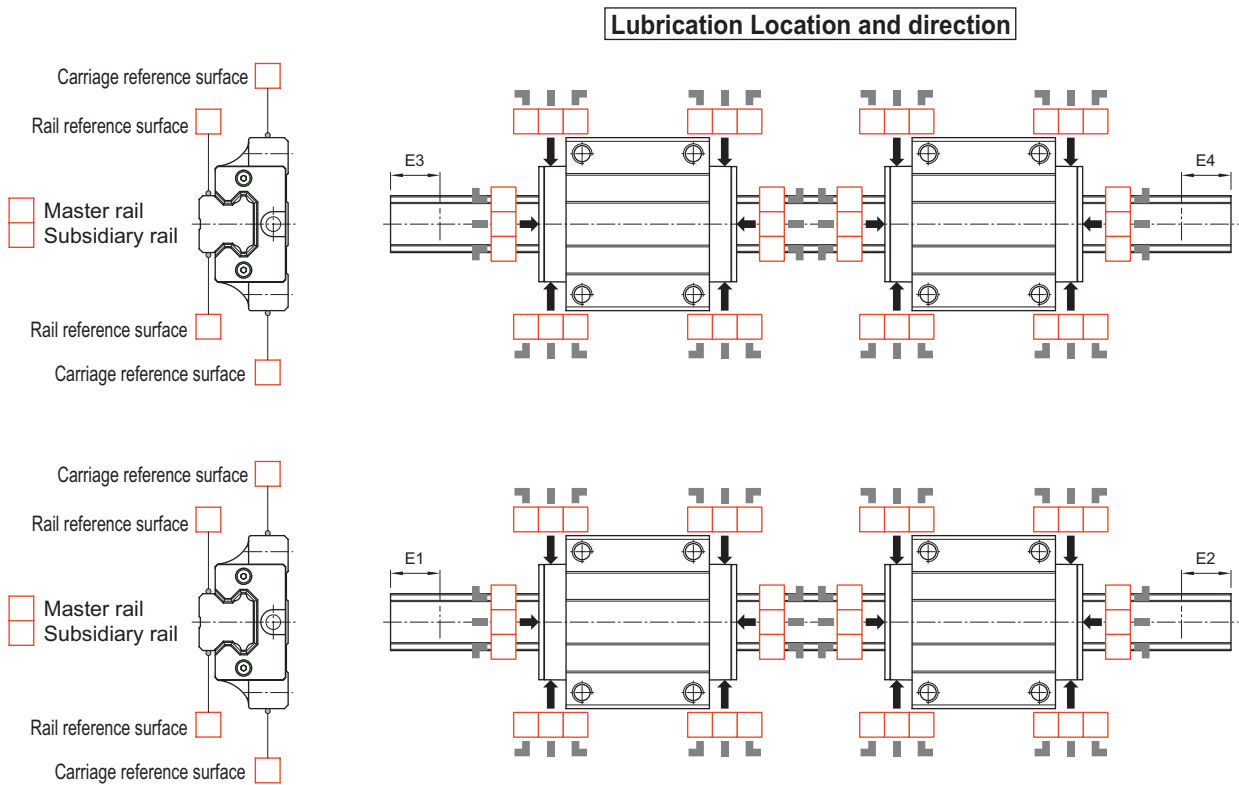

*Unspecified cases followed by **AMT** standards. For other special requirements, please contact us.

The specifications in this catalogue are subject to change without notification.