



Miniature Linear Guideway

**MSC Stainless Steel Series**

[www.pmi-amt.com](http://www.pmi-amt.com)

# Content

<b>1</b>	Construction	01
<b>2</b>	Characteristics	01
<b>3</b>	Description of Specification	02
<b>4</b>	Accuracy	03
<b>5</b>	Preload	04
<b>6</b>	Dust Proof	04
<b>7</b>	The Shoulder Height and Corner Radius for Installation	06
<b>8</b>	Dimensional Tolerance of Mounting Surface	07
<b>9</b>	Rail Standard and Maximum Length	07
<b>10</b>	Dimensions of MSC-M/MSL-LM	08



# Miniature Linear Guideway

## MSC Stainless Steel Series

### 1 Construction

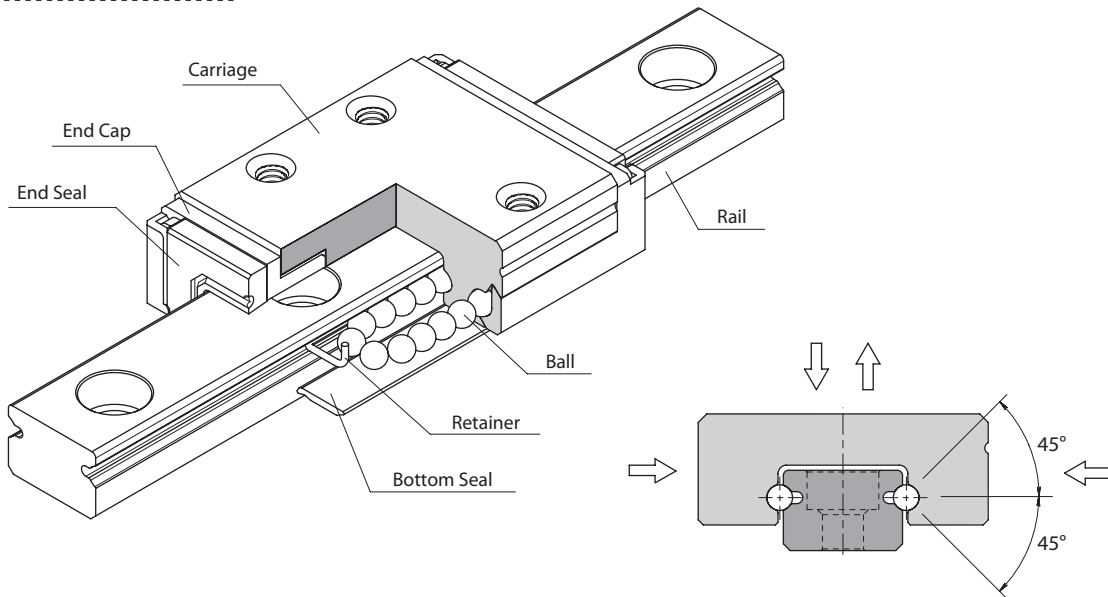

### 2 Characteristics

MSC stainless steel series are applied two rows with Gothic-arch groove and designed to contact angle of 45° which enables it to bear an equal load in radial, reversed radial and lateral directions. Furthermore, ultra compact and low friction resistance design is suit to compact equipment. The lubrication route makes the lubricant evenly distribute in each circulation loop. Therefore, the optimum lubrication can be achieved in any installation direction, and this promotes the performance in running accuracy, service life, and reliability.

#### Four-way Equal Load

The two trains of balls are allocated to a Gothic-arch groove contact angle at 45°, thus each train of balls can take up an equal rated load in all four directions.

#### Smooth Movement with Low Noise

The simplified design of circulating system with strengthened synthetic resin accessories makes the movement smooth and quiet.

#### Ultra Compact

The ultra compact design is suit to the compact application with limited in space.

#### Ball Retainer

Design with ball retainer can prevent ball form dropping.

#### Interchangeability

For interchangeable type of linear guideway, the dimensional tolerances are strictly maintained within a reasonable range, and this has made the random matching of the same size of rails and carriages possible. Therefore, the similar preload and accuracy can be obtained even under the random matching condition. As a result of this advantage, the linear guideway can be stocked as standard parts, the installation and maintenance become more convenient. Moreover, this is also beneficial for shortening the delivery time.

### 3 Description of Specification

#### (1) Non-interchangeable Type

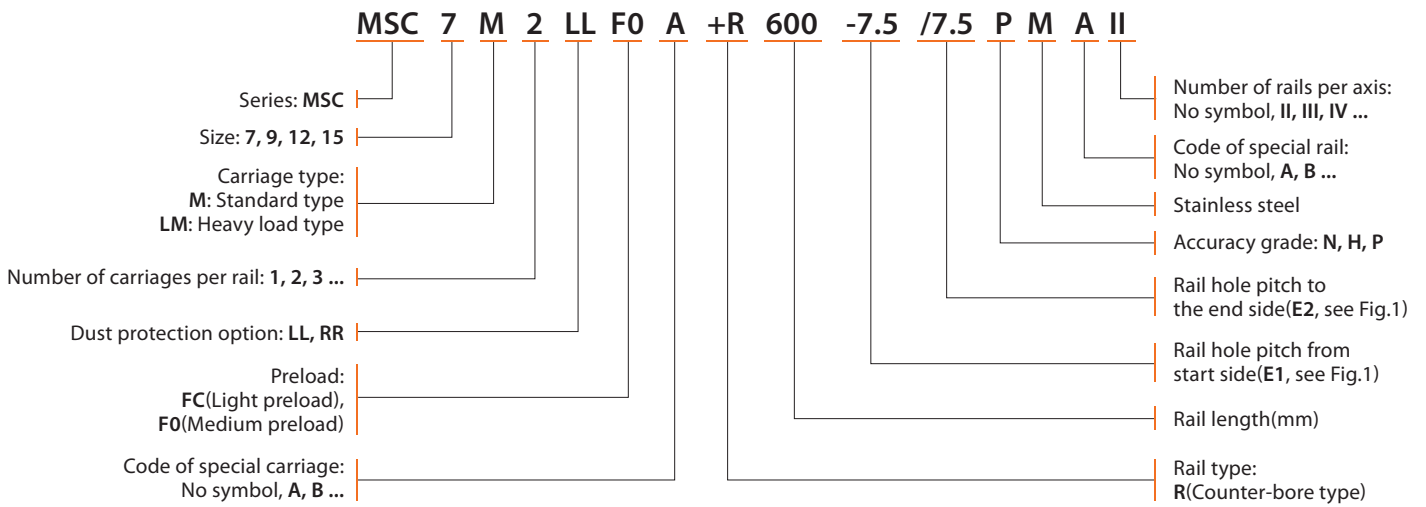
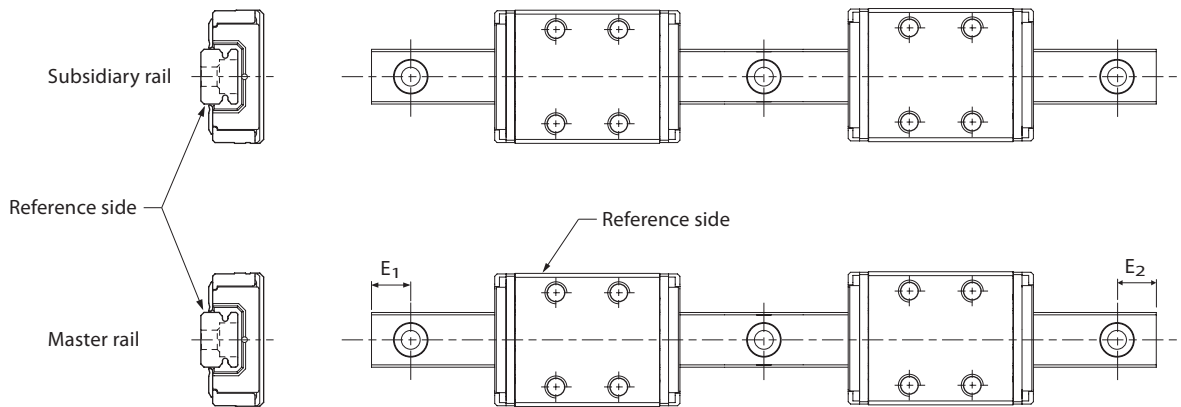
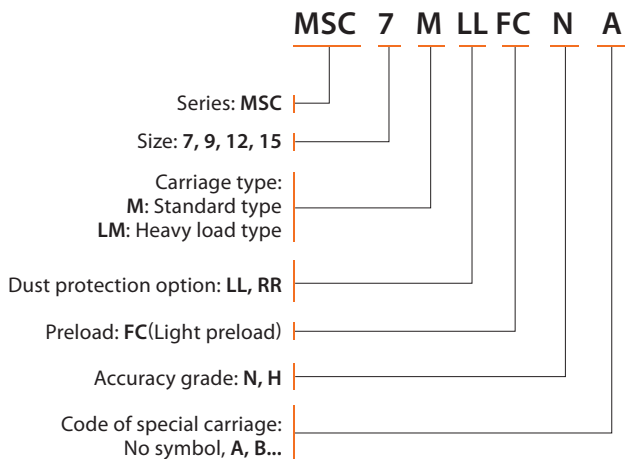

Fig.1



#### (2) Interchangeable Type

##### · Code of Carriage



##### · Code of Rail

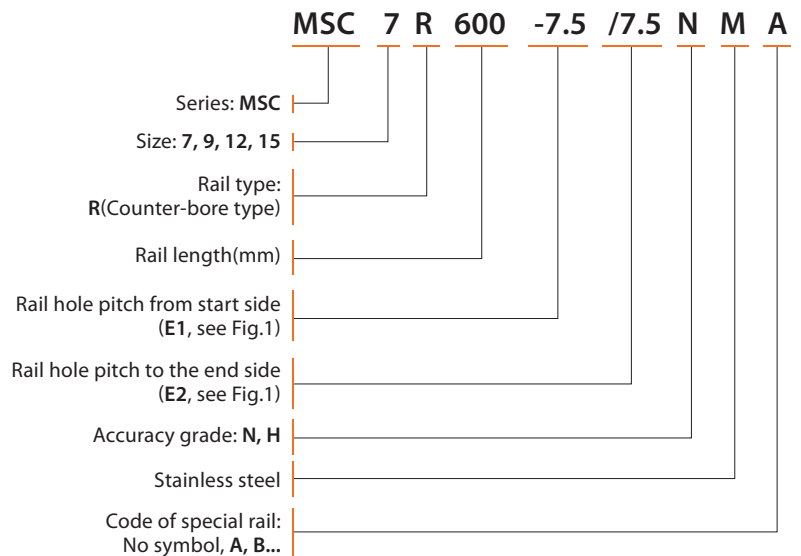

## 4 Accuracy

The accuracy of MSC series is divided into 3 classes, normal grade(N), high precision(H) and precision(P), as shown in Table 1.

### Accuracy Grade

Unit: mm

Model No.	Item	Accuracy Grade		
		Normal N	High H	Precision P
MSC 7	Tolerance for height H	±0.04	±0.02	±0.01
	Height difference ( $\Delta H$ )	0.03	0.015	0.007
MSC 9	Tolerance for distance $W_2$	±0.04	±0.025	±0.015
MSC 12	Difference in distance $W_2(\Delta W_2)$	0.03	0.02	0.01
MSC 15	Running parallelism of surface C with surface A	$\Delta C$ (see Fig.2)		
	Running parallelism of surface D with surface B	$\Delta D$ (see Fig.2)		

■ Table 1

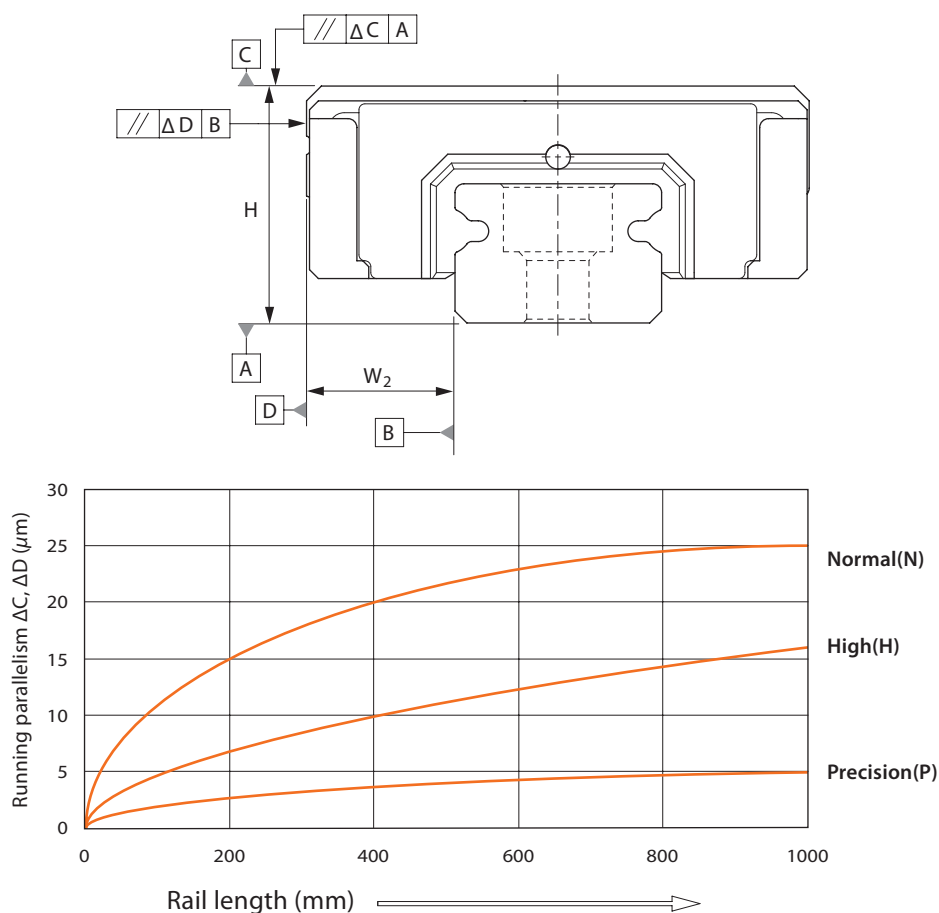

Fig.2 Running Parallelism of Carriage

## 5 Preload

### Preload grade and radial clearance

The preload of MSC series is represented by radial clearance which is divided into two grades, light (FC) and medium (F0), as shown in Table 2.

Preload grade and radial clearance			
Model No.	Preload	Light	Medium
		FC	F0
MSC 7		-2 ~ +2	-3 ~ 0
MSC 9		-2 ~ +2	-4 ~ 0
MSC 12		-3 ~ +3	-6 ~ 0
MSC 15		-5 ~ +5	-10 ~ 0

Unit:  $\mu\text{m}$

■ Table 2

## 6 Dust Proof

### (1) Contamination protection

MSC series of linear guideway offers various kinds of dust protection accessory to keep the foreign matters from entering into the carriage.

#### · End seal

Monodirectional seal for low frictional resistance required.

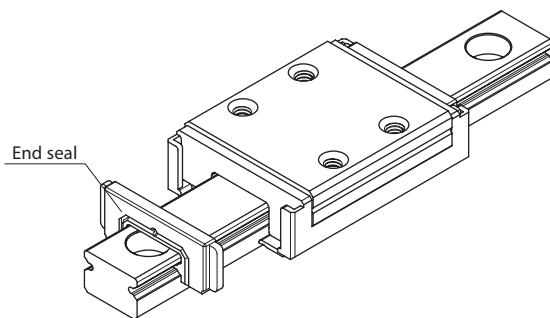

#### · Bottom Seal

Preventing the inclusion of foreign matters from bottom of carriage.

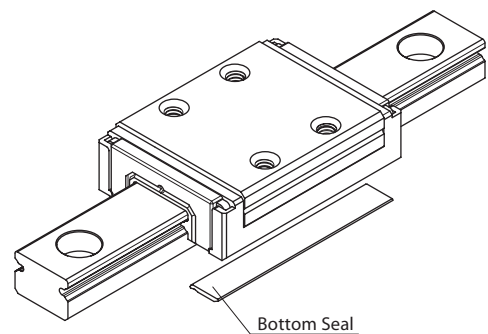

### (2) Code of contamination protection

The codes for selection of dust protection accessory are shown as Table 3.

#### Code of contamination protection

Code	Contamination protection
LL	Low frictional end seal (both end)
RR	Low frictional end seal + Bottom seal

■ Table 3

### (3) Resistance value of Seal

The maximum resistance value of seals type LL when it is applied with grease is shown as Table 4.

#### Seal resistance value

Unit: N

Model No.	Resistance
MSC 7	0.08
MSC 9	0.1
MSC 12	0.4
MSC 15	0.8

■ Table 4

#### (4) Caps for rail mounting hole

A special designed of cap is used to cover the bolt hole to prevent the foreign matters from entering the carriage. The cap is mounted by using a plastic hammer with a flat pad placed on the top, until the top of cap is flush to the top surface of rail (see Fig. 3).

The dimension of caps for different sizes of rail is shown as Table 5.

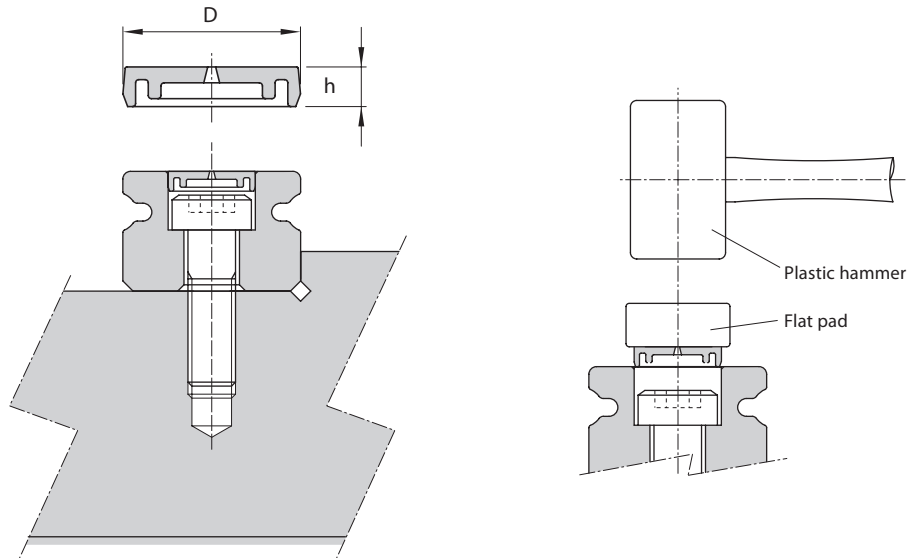

Fig.3 Cap for rail mounting hole

#### Dimension of caps

Model No.	Code of Cap	Bolt size	D(mm)	h(mm)
MSC 7	-	M2	-	-
MSC 9	-	M3	-	-
MSC 12	M3C	M3	6.3	1.0
MSC 15	M3C	M3	6.3	1.0

■ Table 5

## 7 The Shoulder Height and Corner Radius for Installation

The mounting surface of rails and carriages are machined precisely for aiding in positioning and assemble with high accuracy. The shoulder height and corner radius providing enough mounting space for not to interfere with chamfers made on rails and carriages.

The dimensions of shoulder height and corner radius are shown as Table 6 and with bottom seal are shown as Table 7.

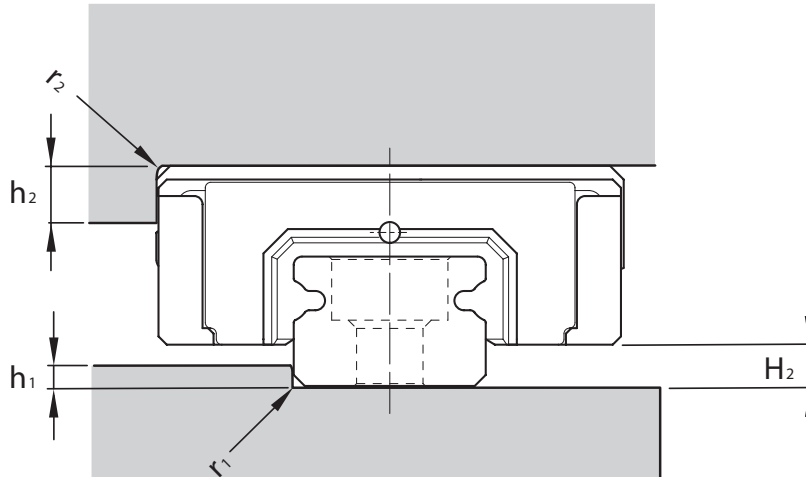

Shoulder height and corner radius of mounting surface

Unit:mm

Model No.	$r_1$ (max.)	$r_2$ (max.)	$h_1$	$h_2$	$H_2$
MSC 7	0.2	0.2	1.0	3	1.5
MSC 9	0.2	0.3	1.7	3	2.2
MSC 12	0.3	0.4	2.5	4	3.0
MSC 15	0.5	0.5	3.5	5	4.0

■ Table 6

Shoulder height and corner radius of mounting surface with bottom seal

Unit:mm

Model No.	$h_1$	$H_2$
MSC 7	0.9	0.9
MSC 9	1.6	1.6
MSC 12	2.4	2.4
MSC 15	3.4	3.4

■ Table 7

## 8 Dimensional Tolerance of Mounting Surface

The tolerances of parallelism between two axes are shown as below.

### The parallel deviation between two axes ( $e_1$ )

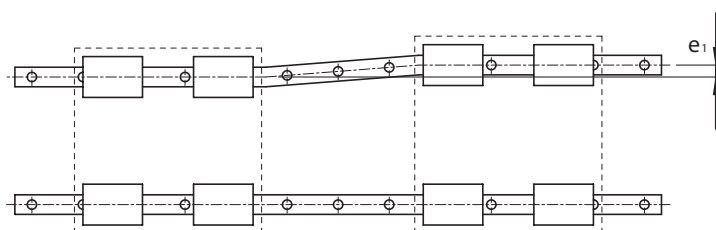

### Parallel deviation ( $e_1$ )

Unit:  $\mu\text{m}$

Model No.	Preload Grade	
	FC	F0
MSC 7	3	3
MSC 9	4	3
MSC 12	9	5
MSC 15	10	6

■ Table 8

### Level difference between two axes ( $e_2$ )

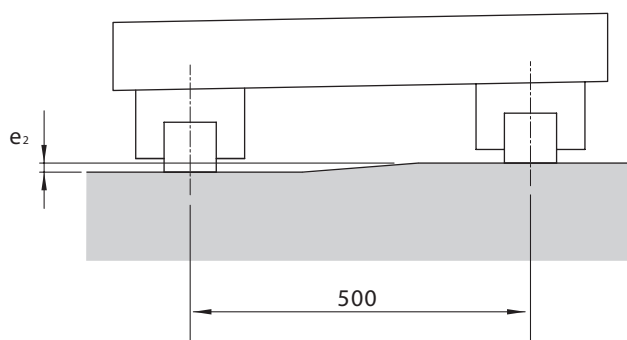

### Level difference between two axes ( $e_2$ )

Unit:  $\mu\text{m}$

Model No.	Preload Grade	
	FC	F0
MSC 7	25	6
MSC 9	35	6
MSC 12	50	12
MSC 15	60	20

■ Table 9 **Note:** The permissible values in table are applicable when the span is 500mm wide.

## 9 Rail Standard and Maximum Length

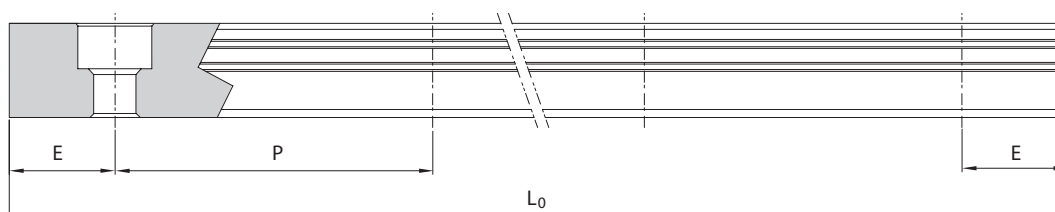

Unit: mm

Model No.	MSC 7	MSC 9	MSC 12	MSC 15
Rail Standard Length ( $L_0$ )	40 55 70 85 100 130	55 75 95 115 135 155 175 195 275 375	70 95 120 145 170 195 220 245 270 320 370 470 570	70 110 150 190 230 270 310 350 390 430 470 550 670 870
Standard Pitch (P)	15	20	25	40
Standard (E)	5	7.5	10	15
Max. Length ( $L_0$ )	600	1000	1000	1000

## 10 Dimensions of MSC-M / MSC-LM

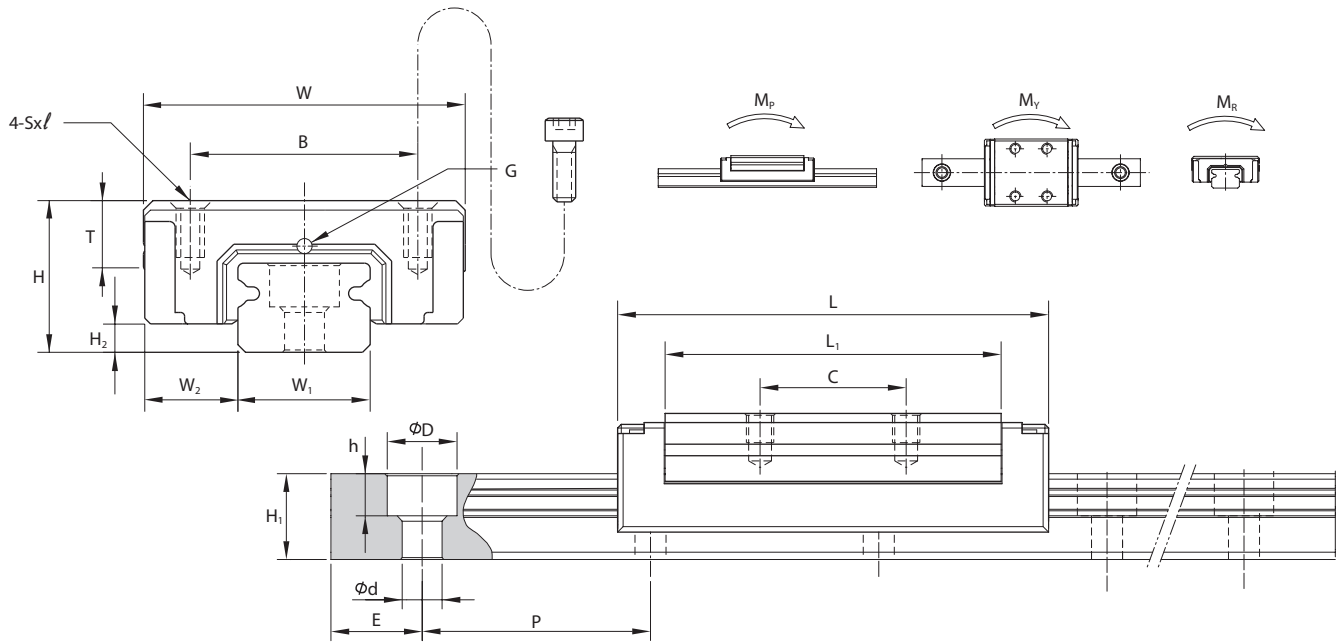

Unit: mm

Model No.	External dimension					Carriage dimension					
	Height H	Width W	Length L	W <sub>2</sub>	H <sub>2</sub>	B	C	Sx/l	L <sub>1</sub>	T	G
MSC 7 M MSC 7 LM	8	17	23.6 33.1	5	1	12	8 13	M2x2.5	18.4 27.9	3.5	φ0.8
MSC 9 M MSC 9 LM	10	20	31.1 41.3	5.5	2.2	15	10 16	M3x3	25.8 36	4.5	φ1
MSC 12 M MSC 12 LM	13	27	34.6 47.6	7.5	3	20	15 20	M3x3.6	28 41	6	φ1.5
MSC 15 M MSC 15 LM	16	32	43.5 60.5	8.5	3.7	25	20 25	M3x4.2	36.1 53.1	7	G-M3

Model No.	Rail dimension					Basic load rating		Static moment rating			Weight	
	Width W <sub>1</sub>	Height H <sub>1</sub>	Pitch P	E std.	D x h x d	Dynamic C kN	Static C <sub>0</sub> kN	M <sub>p</sub> N-m	M <sub>y</sub> N-m	M <sub>r</sub> N-m	Carriage g	Rail kg/m
MSC 7 M MSC 7 LM	7 <sup>0</sup> <sub>-0.05</sub>	4.7	15	5	4.2x2.3x2.4	0.94 1.36	1.28 2.24	2.6 7.4	2.6 7.4	4.7 8.3	13 18	0.22
MSC 9 M MSC 9 LM	9 <sup>0</sup> <sub>-0.05</sub>	5.5	20	7.5	6x3.3x3.5	1.71 2.52	2.24 3.92	6.1 17.4	6.1 17.4	10.8 18.8	29 39	0.33
MSC 12 M MSC 12 LM	12 <sup>0</sup> <sub>-0.05</sub>	7.5	25	10	6x4.5x3.5	2.62 3.77	3.52 5.72	11.4 28.3	11.4 28.3	22.2 36.0	40 60	0.63
MSC 15 M MSC 15 LM	15 <sup>0</sup> <sub>-0.05</sub>	9.5	40	15	6x4.5x3.5	4.52 6.47	5.70 9.26	24.7 61.0	24.7 61.0	44.4 72.2	71 100	1.02

# AMT Linear Guideway Request Form

Date :

Customer Name :		Address :					
Tel :		Machine Type :					
Fax :							
Contact Person :		Drawing No. :					
Installation Direction							<input type="checkbox"/> Others
	<input type="checkbox"/> H type	<input type="checkbox"/> R type	<input type="checkbox"/> V type	<input type="checkbox"/> K type	<input type="checkbox"/> T type	<input type="checkbox"/> RV type	
Carriage Type	MSC - <input type="checkbox"/> M <input type="checkbox"/> LM						
Size	<input type="checkbox"/> 7 <input type="checkbox"/> 9 <input type="checkbox"/> 12 <input type="checkbox"/> 15						
No. of Carriages	<input type="checkbox"/> 1 <input type="checkbox"/> 2 <input type="checkbox"/> 3 <input type="checkbox"/> 4 <input type="checkbox"/> Others :						
Dust Protection	<input type="checkbox"/> LL <input type="checkbox"/> RR						
Preload Grade	<input type="checkbox"/> FC <input type="checkbox"/> F0						
Rail Type	<input type="checkbox"/> Counter-bore (R type)						
Rail Length & Pitch	Length :                      E <sub>1</sub> :                      E <sub>2</sub> :                      E <sub>3</sub> :                      E <sub>4</sub> :						
Accuracy Grade	<input type="checkbox"/> N <input type="checkbox"/> H <input type="checkbox"/> P						
Rail per Axis	<input type="checkbox"/> 1 <input type="checkbox"/> 2 <input type="checkbox"/> 3 <input type="checkbox"/> Others :						
Full Code of Specification							
Required Quantity							

## Reference surface

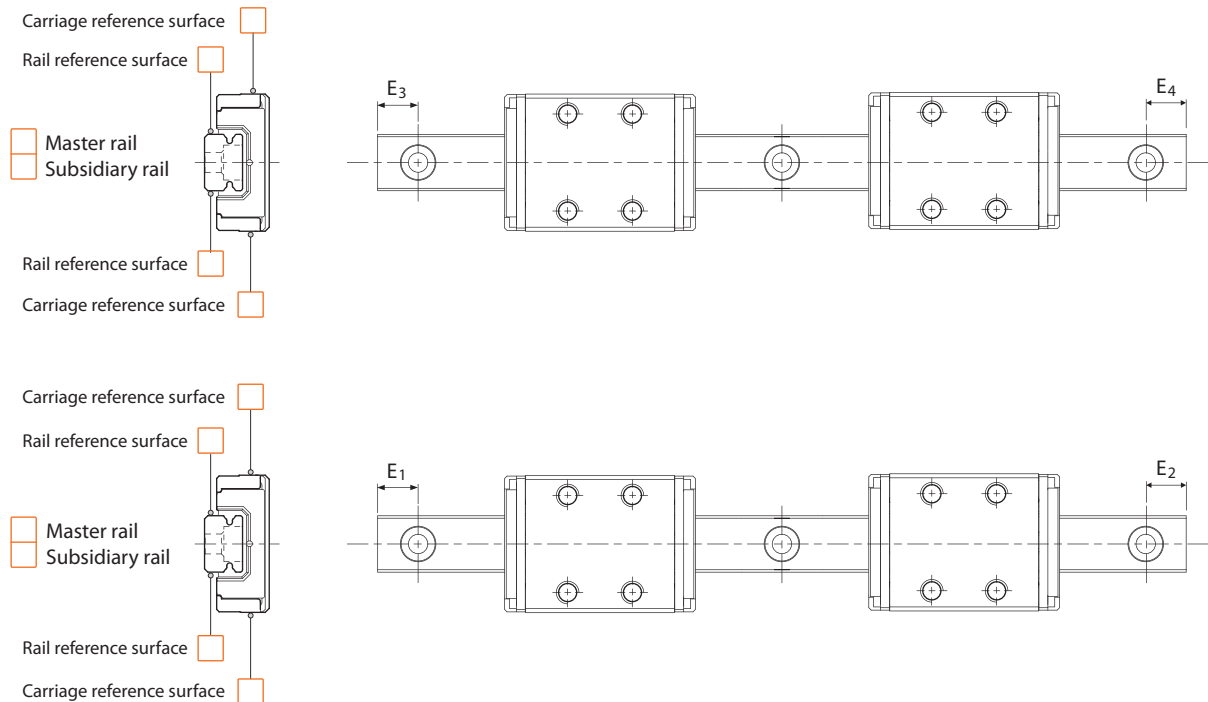

\* Nonspecified cases followed by **AMT** standards. For other special requirements, please contact us.

The specifications in this catalogue are subject to change without notification.